



Operators Manual

Transfer Auger



Contents

Introduction	4
Serial Number Location	4
Disclaimer	4
Induction Sheet for Operators.....	5
Grainline Warranty Registration	6
Grainline Warranty Conditions.....	6

Section 1: Safety Information

1.1 Hazard Labels	7
1.2 General Safety	7
1.3 Intended Use	7
1.4 Correct Usage	7
1.5 Incorrect Usage	8
1.6 Transportation Safety	8
1.7 Safety Decals	8
1.8 Diagram of Decal Placement	10
1.9 Location and Usage of Safety Devices & Guarding	10
1.10 Transportation	11
1.11 Towing procedure.....	11

Section 2: Installation

2.1 Undercarriage Assembly	11
----------------------------------	----

Section 3: Operation

3.1 Before Operation	12
3.2 Initial Running of the Grain Auger	12
3.3 Pre-operation checklist	13
3.4 Drive System	13
3.5 Start up and break in procedure	14
3.6 Full Load Procedure	14
3.7 Completion and cleanup.....	14

Section 4: Lubrication & Maintenance

4.1 Maintenance	15
4.2 Upper Chain Drive	16
4.3 Drive Belts	17
4.4 Bearings	18
4.5 Fasteners	18
4.6 Wheel hubs	18
4.7 Tyre Pressure	18
4.8 Engine Servicing	18
4.9 Lubrication	18
4.10 Checking engine crankcase oil level	18
4.11 Changing oil	19
4.12 Air Cleaner Servicing	20
4.13 Spark Plug Service	20

Section 5: Storage

5.1 Long Term Storage 21

Section 6: Specifications

6.1 Transfer Auger Specifications 21
6.2 Transfer Auger Dimensions 21

Grainline Warranty Registration

Please ensure that you complete the warranty registration for your transportable auger as directed below. This will ensure that your details as the owner are accurate and allow a faster response time to any issues that may arise.

To complete your warranty registration please scan
the QR code or go to:

www.grainline.com.au/warranty-registration



Grainline Warranty Conditions

Limited 2 year warranty for all products manufactured by Grainline.

What this warranty will cover.

Grainline will at its own discretion, repair or replace without charge any part of our products which may be found defective in material and/or workmanship within 24 months of the original purchase date.

At Grainline's request the customer will make the defective part available for inspection by Grainline or a dealer of Grainline products so that the cause of the faulty / defective part can be identified for accurate repair.

All parts used and manufactured on Grainline products are covered by this warranty except for the following components, which are covered by their respective manufacturer's warranty.

- Honda Engines 1300 246 632 - poweredby.honda.com.au/Warranty
- Vanguard Engines 1300 274 447 - vanguardengines.com/service-support
- Kohler Engines 02 9830 2305 - epgengines.com.au/contact-EPG-engines
- It is the owner's responsibility to transport defective parts and/or units to their local service dealer who can negotiate a call-out fee at the owner's expense.
- A warranty form must be completed and sent to Grainline and authorisation is needed before a service dealer is able to commence any repairs on Grainline products.

What this warranty will not cover.

- Defects caused by depreciation or damage caused by normal wear, accidents, improper maintenance, improper use and abuse of the product, alterations, or failure to follow the instructions contained in the owner's manual for operation and maintenance.
 - Transport cost for making Grainline products available for inspection and/or repair to and from the place where the warranty work is performed.
-

How to obtain service under this warranty.

Warranty service can be arranged by contacting either your Grainline Dealer or Grainline direct on 1800 810 498. Please have the auger model and serial number available as this will be required by the service technician.

1. Safety Information

The owner is responsible for the safe operation and maintenance of this equipment. Please note that information of special importance has been highlighted in this manual using the below signal words.

1.1 Hazard Labels

DANGER

Indicates an imminently hazardous situation that, if not avoided, will result in serious injury or death.

WARNING

Indicates a hazardous situation that, if not avoided, could result in serious injury or death.

CAUTION

Indicates a hazardous situation that, if not avoided may result in minor or moderate injury.

NOTICE

Indicates a potentially hazardous situation that, if not avoided, may result in property damage

1.2 General Safety

The Grainline grain auger must not be used when the operator is:

- Taking medication that causes drowsiness.
- Under the influence of alcohol or drugs
- Incompetent
- Not aware of the operating procedures

Manufacturers, retailers, owners, and operators all have responsibilities with regards to safety. Be aware of your responsibilities and carry them out. The owner or designated officer is responsible for the safe operation and maintenance of this equipment. The most important part of safe operation is a safety conscious operator who always remembers to:

- Keep children away from grain auger work area.
- Be aware of overhead electrical lines. Electrocutation can occur without direct contact.
- Do not operate grain auger with any safety shield, cover or guard removed.
- Keep body, hair, and clothing away from all moving parts.
- Inspect drive belts, drivelines, cables, bolts and nuts and intake area before operating grain auger.
- Replace, repair, tighten and clean out any parts or areas that need attention.
- Keep well away from grain auger intake during operation.
- Petrol engines to be operated in an adequately ventilated area.

1.3 Intended Use

The Grainline Transfer Auger has been designed and manufactured, to assist in the safe and effective transfer of various grain types. Use of the auger in any other way is considered as misuse and is not covered by the warranty.

1.4 Correct Usage

The Grainline auger must be used in accordance with the safety instructions contained within this manual. Only competent personnel who have received proper training and are familiar with the machine should operate and perform any service work on the auger. When the auger is being used hearing protection must be worn, and it is the owner's responsibility to provide the appropriate hearing protection to all others involved in the operation of the auger. When the auger is not in use, it must be immobilized – i.e., turned off and key removed from the power source. Please note, where guards and safety features are removed in this manual it is for illustration purposes only.

1.5 Incorrect Usage

The Grainline auger must not be used for anything other than the intended purpose set out by Grainline.

Incorrect use of the auger includes:

- Using the auger as a hoist or crane.
- Using the auger to transfer grains or materials other than dry, free-flowing food grains.

WARNING: Any modification to the Grainline auger without the approval of Grainline will void all warranty and could result in death or serious injury.

1.6 Transportation Safety



- Check applicable state or territory laws and regulations before transporting.
- Always travel at a safe speed and never exceed 50 kph.
- Never transport in fog, snow, or heavy rain.
- Fully lower the auger before transporting and only raise when next to a storage facility.
- When towing always attach safety chains and use a suitable towing vehicle with a pin and retainer.
- Empty all grain out of the auger prior to transporting.
- Ensure axles are fully retracted and secured prior to towing.

1.7 Safety Decals

Samples of the safety decals here are those used on the Grainline transfer augers.

WARNING: Regularly read all safety decals that appear on your Grainline auger and replace them if damaged. Failure to do so could result in serious injury or death.

Decal No.	Decal Explanation	Decal Detail
Decal 1.	<p style="text-align: center;">EXPOSED ROTATING FLIGHTING</p> <ul style="list-style-type: none"> - Keep hands, feet, and clothing away from intake. - Keep guarding in place. 	 <p>The decal features a red oval with the word 'DANGER' in white. Below this, the text reads: 'EXPOSED ROTATING FLIGHTING', 'Keep hands, feet and clothing away from intake.', 'Keep guarding in place and in good working order.', 'If outer guard is required to be removed, an alternative means must be adapted to ensure flighting is guarded to the required standard.', and 'Failure to do so will result in serious injury or death.' At the bottom is a pictogram of a person being struck by a rotating auger.</p>

<p>Decal 2.</p>	<p style="text-align: center;">ROTATING FLIGHTING HAZARD</p> <ul style="list-style-type: none"> - Warns of rotating flighting hazard on the intake of the grain auger. - Sets out the steps to follow for the safe operation of the grain auger. 	 <p>CAUTION</p> <p>ROTATING FLIGHTING HAZARD</p> <ol style="list-style-type: none"> 1. Read and understand the operators manual before operating equipment. 2. Keep all safety guards and devices in place and in good working order. 3. Ensure everyone is clear before operating equipment. Keep all children, visitors and untrained personal away at all times. 4. Keep hands, feet, hair and clothing away from all moving parts. 5. Do not run auger empty. 6. Hearing protection must be worn. 7. Switch off power, disconnect hydraulic/ PTO or stop engine to adjust, service or clean the equipment. 8. Make sure electric motors are earthed. 9. Disconnect power before restarting overloads or electric motors. 10. Always lower before moving and when not in use. 11. Trained personal must be in attendance when equipment is being operated.
<p>Decal 3.</p>	<p style="text-align: center;">ROTATING DRIVE HAZARD</p> <ul style="list-style-type: none"> - Keep guarding in place and in good working order. - Do NOT operate if guarding has been removed. 	 <p>DANGER</p> <p>ROTATING DRIVE HAZARD</p> <p>Keep guarding in place and in good working order. Do not operate if guarding has been removed.</p> <p>Failure to do so will result in serious injury or death.</p>
<p>Decal 4.</p>	<p style="text-align: center;">DO NOT RUN AUGER EMPTY</p> <ul style="list-style-type: none"> - Hearing protection must be worn. - Keep electric motor and leads protected against moisture. 	 <p>WARNING</p> <p>DO NOT RUN AUGER EMPTY</p> <p>Hearing protection must be worn.</p> <p>Keep electric motor and leads protected against damage and moisture.</p> <p>Failure to do so may result in serious injury or death.</p>

1.8 Diagram of Decal Placement



1.9 Location and Usage of Safety Devices & Guarding

Emergency Stop Switch

It is important to check that the emergency stop switch is working correctly prior to every use of the auger. The emergency stop switch is located close to the auger intake to enable the operator to quickly stop the auger in an emergency.



Auger Flying Guard

The auger intake guarding consists of fixed inner bars with an outer guard fixed to the top of the hopper. To ensure operator safety, the hopper must stay attached to the auger.



Belt, Shaft and Chain Guards

All drive and motion parts including drive shafts, couplings, drive chains and drive belts are covered by guards and shields to ensure maximum operator safety. If any guards or shields are removed for service and maintenance, they must be reinstalled immediately after work is complete.

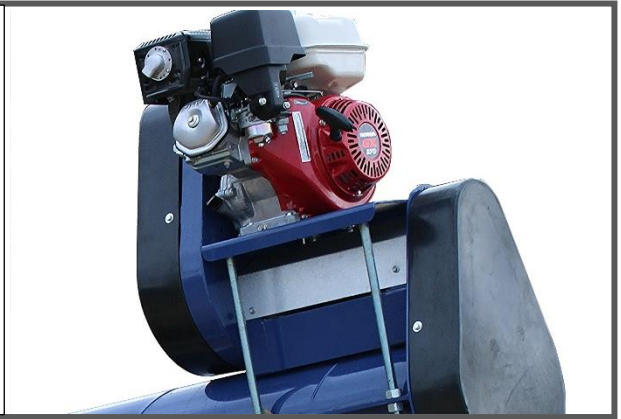

1.10 Transportation

The Grainline Transfer augers have been designed and engineered to allow them to be safely transported on a public road or property.

- Check applicable state laws and regulations before transporting.
- Always travel at a safe speed.
- Never transport augers in fog, snow or heavy rain.
- Fully lower the auger before transporting.
- When towing always attach safety chains and use an approved tow coupling.
- Empty all grain/seed out of the auger before transporting.

1.11 Towing Procedure

- Place auger in its lowest position.
- Equip the tow vehicle and auger with any flashing beacons, signs and flags as required by your state's road authority.
- Connect the auger to the tow vehicle, ensuring that the tow coupling is fully secured, and safety chains are fitted.
- When towing use caution when turning and cornering.
- Stop after 20 kilometres and check the following: Wheel bearings for overheating or excessive play. Safety chains, tow coupling and visually check all fasteners.

NOTICE: Always check tyre pressure before towing, recommended pressure for towing is 15 psi. It is recommended that the hopper is removed to prevent possible damage to the hopper and tow vehicle when turning sharply.

Section 2: Installation

2.1 Undercarriage Assembly

Safe operating procedure

- Assemble the grain auger on a level surface.
- Use approved slings with a working load limit of at least 1 tonne to raise the augers.
- Use the correct tools.
- Assembly only to be done by competent persons.

Assembly

1. Fit undercarriage arms to the axle and secure with arm retaining collars. See figure 1 below.
2. Clean stub axles and proceed to fit wheel hubs. The order of hub fitment onto the stub axle is as follows. Dust seal, large roller bearing, hub, small roller bearing, flat washer, slotted spindle nut, split pin and finally the hub cap. Ensure that the hubs rotate freely prior to fitment of the split pin and hub cap.
3. Fit wheels to hubs and tighten all wheel nuts.
4. Using a suitable sling, raise discharge end of auger up to a height that will allow the assembled undercarriage to fit below. Slide the assembled undercarriage underneath the auger barrel.
5. Raise the arms and attach to the bracket at desired height and balance setting.
6. Ensure all bolts are correctly fitted and tightened then proceed to remove support sling from auger.

Figure 1.

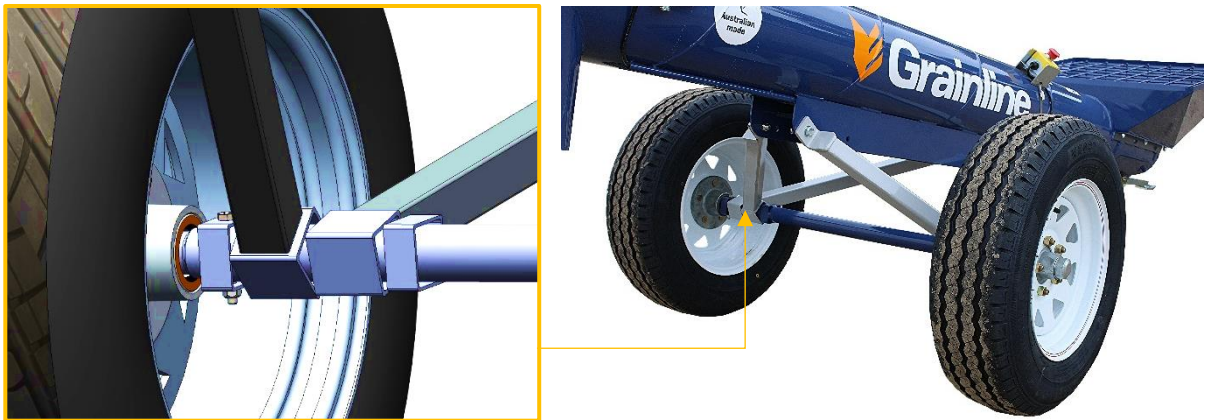

Section 3: Operation

3.1 Before operation

Before moving the grain auger into position for operation, the following pre-operation check must be done.

- Visually check all nuts and bolts.
- Ensure that there are no obstructions in the intake.

WARNING: Anchoring and support of the auger during operation is necessary. When the lower half of the auger becomes empty, the grain moving to the top transfers the weight balance to the upper end of the auger, which can cause up-ending.

Placement procedure

- Ensure the grain auger wheels are always on level ground.
- Move the auger to its working position and chock wheels on both sides.

3.2 Initial running of the grain auger

Safe operating procedure

1. Before attempting to start the engine, study the engine manufacturer's operator's instructions. Familiarise yourself with the starting and shut down procedures of the engine.
2. Check engine oil and fuel.
3. Ensure that the area around the auger is clear of people and animals, and the intake area is unobstructed.
4. Be ready to shut down the engine in case of an emergency.

5. Exhaust fumes in an enclosed area are deadly; only operate petrol engines in an adequately ventilated area.
6. Running of the grain auger only to be done by competent persons.

Procedure

1. Ensure throttle is set at idle position then proceed to start engine.
2. Move throttle to engage centrifugal clutch and take to approximately half revs.
3. If there is no undue noise and vibration, run the auger for a further 15 seconds to check if the grain auger is running correctly.

NOTICE: An empty auger will always run with greater noise and vibration levels. Once grain starts flowing through the auger, noise and vibration levels will decrease.

3.3 Pre-operation checklist

Efficient operation of the grain auger requires that competent operators follow a checklist and be familiar before each start up and demands that safety precautions be observed at all times. To do otherwise is endangering life and limb and is a misuse of equipment.

Before operating the auger for the first time and each subsequent time, the operator must follow a checklist and be familiar with all facets of moving grain with an auger.

Checklist

- All safety guards and shields are in place and secure.
- Drive belts are not frayed and are properly adjusted.
- Drive train and sprockets are in line and correctly tensioned.
- All fasteners are tight or properly adjusted.
- Wheel bearings are correctly adjusted.
- Auger wheels are properly chocked.
- Hearing protection is worn.

NOTICE: Correct operation of the grain auger requires pre-inspection of the drive system, operator knowledge on how to shut down the system and general monitoring of the system during operation.

3.4 Drive system

Before starting the engine ensure:

- Petrol tank is properly closed.
- Oil level is correct.
- Area around auger is properly ventilated.
- Pulleys are aligned and secure.
- Follow engine manufactures instructions according to their operator's manual.

NOTICE: In the case of an emergency shutdown, the operator of the grain auger must be fully conversant with all engine controls and shut down procedures.

3.5 Start up and break in procedure

Safe operating procedure

- Ensure you have completed the pre-operation checklist.
- Wear hearing protection.

Procedure

- If everything is satisfactory, prepare for a 5 minute operation at half speed, followed by a 5 minute operation at three quarters speed.
- Start the auger, set at half throttle, start grain flow and run for 5 minutes, listening for undue noise and vibration. If grain auger functions normally, increase the speed to $\frac{3}{4}$ for 5 minutes.
- After completion of the initial run, slow auger down and run until empty, then shut down engine.
- Conduct a complete inspection of the grain auger, referring to the pre operation check list. After initial startup and inspection, the grain auger should be shut down and inspected at least three times during the first ten hours of operation.
- Once the grain auger has been run in, the pre-operation checklist should be part of the daily routine before operating the grain auger.

CAUTION: Chock wheels to prevent auger from unexpectedly moving. Extra care should be taken on sloped or uneven ground. Care should be taken when pushing auger, avoid uneven ground and ground obstacles.

3.6 Full load procedure

Safe operating procedure

- Ensure auger is anchored to prevent upending.
- Do not repair, clean, or adjust the auger while it is in operation.

Procedure

- When operating the auger, always work with a second person in a position to monitor the operation and initiate a shut down in the case of an emergency.
- Monitor the auger during the actual operation for abnormal noises and vibrations.

Normal shutdown

- Near the end of a load, shut off grain supply if necessary, then decrease the speed of the auger until it is empty of all grain.
- Stop the auger only when it is empty.

3.7 Completion and cleanup

Procedure

- At the completion of an operation, the auger should be moved to a storage area.
- Ensure auger is completely empty of grain.
- Clean entire work area.

Section 4: Lubrication & Maintenance

4.1 Maintenance

The auger must be inspected regularly to ensure it is functioning correctly. All problems identified must be rectified prior to use. All safety features must be maintained to ensure they are functioning as intended. Where parts or components require replacing, replacements must be identical or equivalent to the original parts and components. Proper maintenance on the grain auger means a longer life for the machine and more efficient and safer operation.

Safe operating procedure;

- When performing maintenance with an auger, chock the wheels and take precautions to prevent the auger from upending.
- Wear the correct personal protective equipment.

Maintenance Chart - Recommended Service Intervals - Petrol Engines

Service Item	Daily	8hrs	16hrs	24hrs	32hrs	50hrs	Annually
Check engine oil level	Yellow						
Check guards and shields	Yellow						
Check drive belts	Yellow						
Service upper drive train		Yellow					
Check drive belt tension			Yellow				
Check tyre pressure			Yellow				
Service air filter element *				Yellow			
Tighten bolts & nuts					Yellow		
Check bearings					Yellow		
Change engine oil **						Yellow	Yellow
Replace air filter element *						Yellow	Yellow
Grease wheel hub bearings							Yellow
Service spark plugs							Yellow

* More often in extremely dusty/dirty conditions

** Change engine crankcase oil on new engine after first 8 hours of break-in operation.

WARNING: Poor maintenance not only causes costly breakdowns but can result in serious injury or death.

4.2 Upper chain drive

- Keep chain well lubricated at all times. A layer of lubricant will prevent the chain from seizing between seasons.
- Check chain tensioner roller and ensure free movement. Replace roller if flat spots are present or if it does not spin freely.

Chain Tensioner Roller & Top Chain

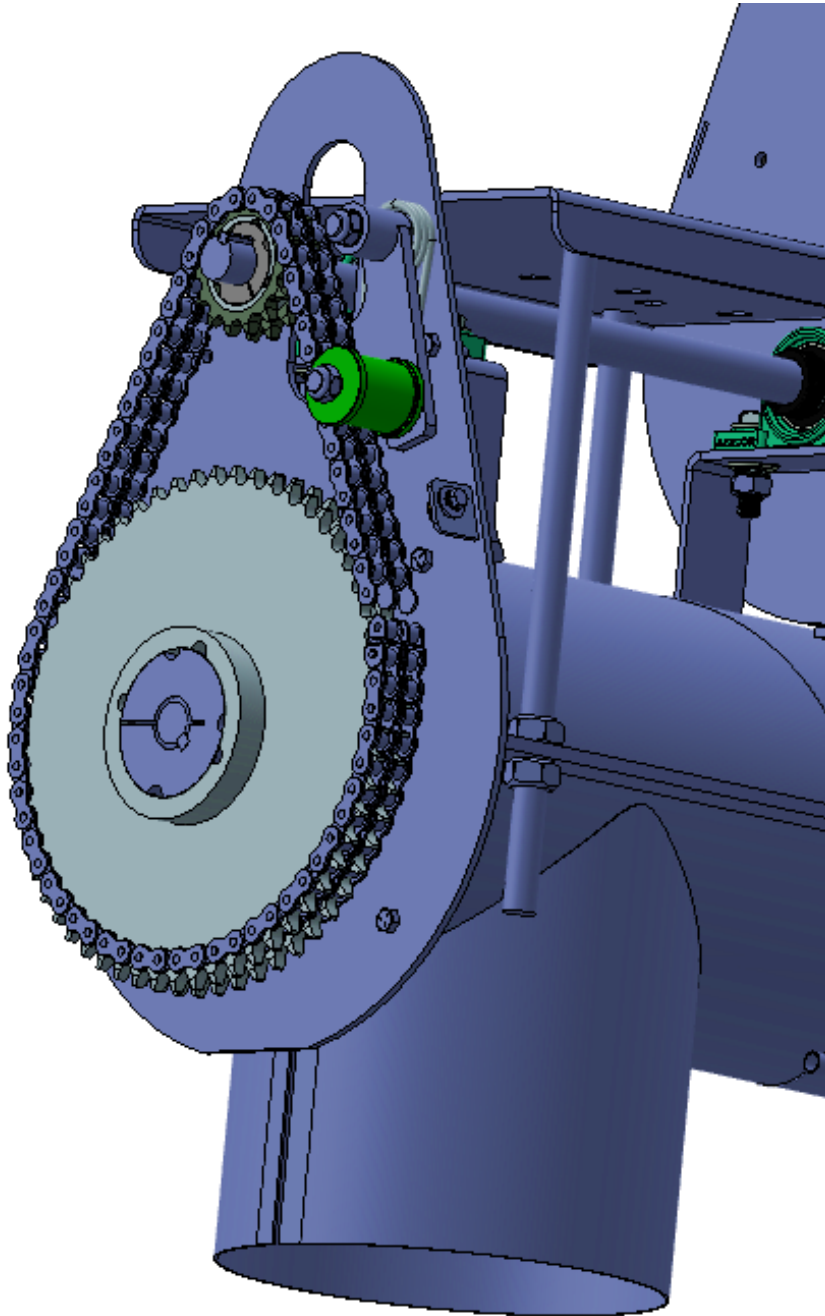

DANGER: Always replace the chain guard after checking or fitting drive chain.

4.3 Drive belts

After the normal initial belt stretch the drive belt will settle in and require checking, and if needed, adjusting every 16 hours.

NOTICE: Replace belt if frayed or damaged. The correct operating belt tension is the lowest tension at which the belts will not slip under peak load conditions.

Belt replacement procedure

1. Ensure engine is turned off.
2. Remove belt guard.
3. Slacken belts by loosening the motor mount nuts.
4. Remove and replace the damaged belts.
5. Replace belt guard.

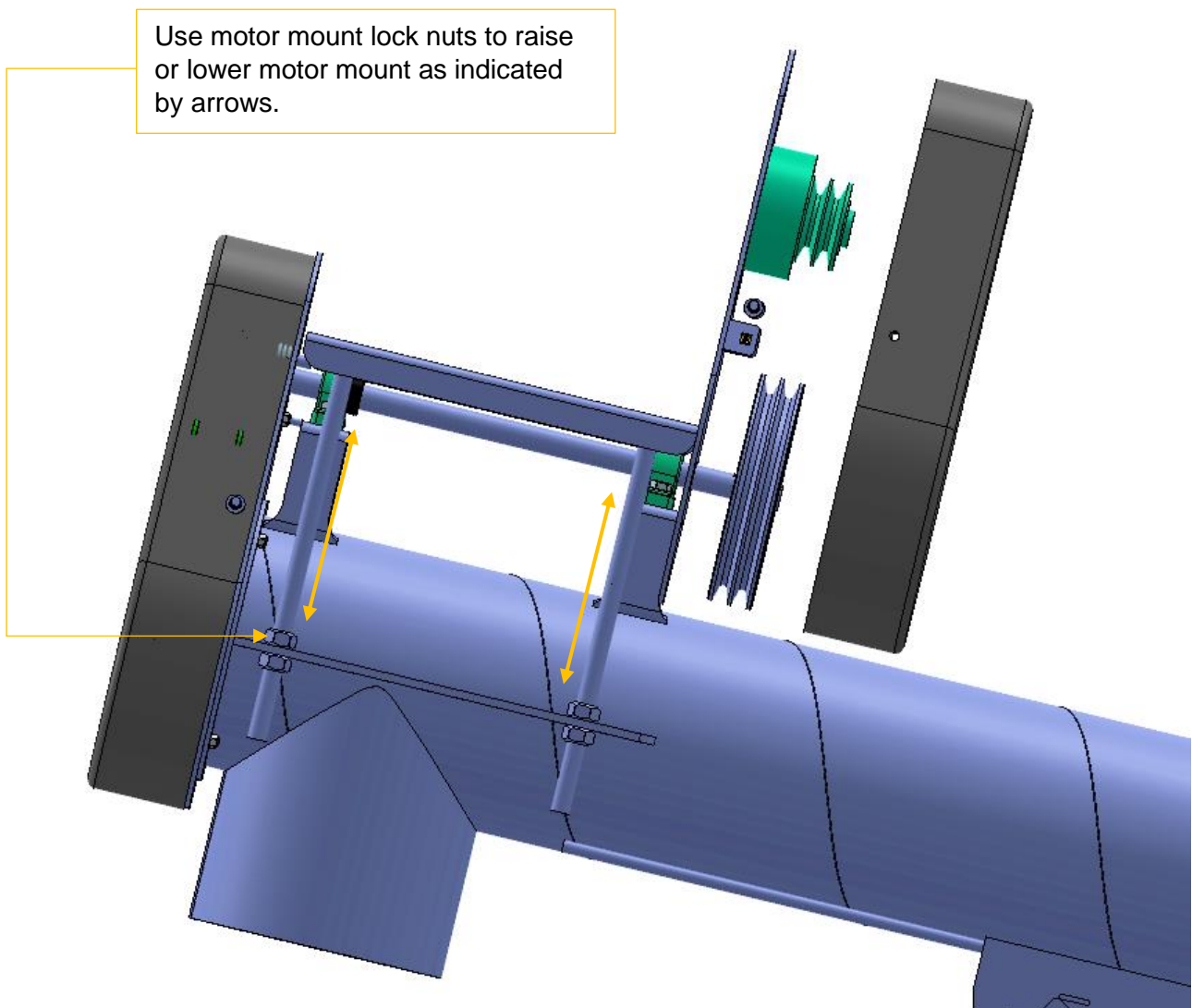

DANGER: Always replace belt guard after checking or fitting drive belt.

4.4 Bearings

1. Remove drive shaft guard.
2. Inspect drive shaft bearings.
3. Ensure all grub screws are tight, and the bearings are sound.
4. Replace drive shaft guard.

DANGER: Never operate the grain auger when the drive shaft guard has been removed.

4.5 Fasteners

1. Check and tighten all bolts, nuts, and grub screws on pulleys, sprockets, lift arms, wheel nuts and engine mounting bolts.

4.6 Wheel hubs

1. Re-pack every 1 – 3 years with lithium based grease.
2. Adjust wheel bearings as per instructions in the assembly section of this manual.

4.7 Tyre pressure

1. Correct pressure should be checked with a suitable pressure gauge and pressure set at 140kPa (20psi).

4.8 Engine servicing

Safe operating procedure:

1. Before attempting to service the engine, remove the ignition key and disconnect the spark plug lead.
2. Refer to engine manufactures manual for servicing and maintenance recommendations.
3. Never check or add oil with the engine running.

4.9 Lubrication

The engine is serviced with 10W30 oil. The oil should be changed after the initial run-in period of 8 hours. Thereafter, change oil after every 50 hours of operation.

4.10 Checking engine crankcase oil level

Check oil level before use and after every 5 hours of continuous operation, or more frequently if engine is exhausting white/blue smoke.

To check oil level

1. Position the auger on a level surface and raise the angle of the auger, by using the winch, until the engine is level. Make sure the engine is cool and oil has had time to drain into the sump, (allow at least 10 minutes after stopping the engine).
2. Before removing the dipstick, clean the area around the dipstick opening of any dirt or debris. Do not allow dirt or dust to enter the engine, or to collect on the dipstick.
3. Unscrew and remove the filler plug/dipstick and wipe off with a clean rag. Screw in, pause, then unscrew and remove the dipstick to check oil level.
4. **The actual oil level is indicated only when the dipstick is screwed in and not rested on top of the crankcase.**
5. The oil level should be kept within the safe range between the **High (H) and Low (L)** marks.

4.11 Changing oil

Change the engine oil after every 50 hours of operation.

CAUTION: Hot oil can burn, never drain engine oil when engine is hot, allow time for the engine to cool down before servicing. Oil only needs to be warm to drain easily.

1. Drain the oil while engine is warm, if the engine is cold run it for a few minutes to warm the oil.
2. Remove the dipstick and oil drain plug. Drain the oil into a suitable container.
3. Allow sufficient time for the oil to completely drain from the engine.
4. Re-install the oil drain plug, ensure it is correctly tightened.
5. Fill the crankcase through the filling point with new oil of the recommended viscosity. Up to 35 degrees Celsius ambient temperature use 10W-30 oil, over 35 degrees Celsius ambient temperature use 10W-40 oil. Correct viscosity will aid starting in cold weather and assure proper lubrication in hot weather.
6. Fill to the full mark on the dipstick. Refer to the previous page for the correct method to check the oil level.
7. Check the dipstick reading before pouring in the last 100ml of oil, fill only to the full mark. Never overfill the crankcase; overfilling can result in overheating and loss of power.
8. Start the engine and check for oil leaks around the oil filler and drain plug. Stop the engine and re-check the oil level, add if necessary. Refer following image for oil fill/dipstick and oil drain locations.

Image below shows oil fill point and dipstick indicated by green arrow and oil drain points indicated by orange arrow.



4.12 Air cleaner servicing

Safe operating procedure:

1. Never use petrol or low flash point solvents to clean the air pre-cleaner or any part of the air cleaner. A fire or an explosion could result.
2. Never run the engine without the air cleaner fitted. Rapid engine wear will result from contaminants such as dust and dirt been drawn into the engine.

Air cleaner servicing

The engine is equipped with a paper air cleaner element and oiled foam pre-cleaner. Clean and re-oil the pre-cleaner after every 24 hours of operation and replace yearly (or when dirty or damaged).

1. Release the air cleaner cover and remove.
2. Remove the foam element from the air cleaner cover and remove the paper element from the air cleaner case.
3. Clean the air filter elements (if they are to be re-used).
4. Foam element-Clean in warm soapy water, rinse and dry thoroughly or clean it in a non-flammable solvent and dry.
5. Always follow engine manufactures recommendations.
6. Paper element: Tap gently on a flat surface to dislodge dirt.
7. Do not wash the paper element, brush the dirt off, use air pressure or damage the side walls of the paper element. Replace the paper element if it is dirty or damaged. Replace element if in doubt.
8. Wipe dirt from the inside of the air cleaner body and cover using a moist rag. Be careful to prevent dirt from entering the air chamber that leads to the carburettor.
9. Re-install the air cleaner elements and cover, ensuring to secure the cover with screws or clips.

4.13 Spark plug service

NOTICE: Never use a spark plug of an incorrect heat range. Refer to engine manufacturers manual for recommended spark plug and servicing details.

1. Yearly, or every 100 operating hours, remove spark plugs, inspect, clean and reset gap or replace with a new plug.
2. Remove each spark plug cap, and using a spark plug wrench, remove each spark plug.
3. Visually inspect the spark plug. Discard the spark plug if there is apparent wear to the electrodes, or if the ceramic insulator is cracked or chipped. Clean the spark plug with a wire brush if it is to be re-used.
4. Measure spark plug gap with a feeler gauge. Correct as necessary by bending the side electrode. Correct gap setting should be 0.7-0.8mm.

Installing spark plug

1. Check that the spark plug washer is in good condition.
2. Screw the spark plug in by hand to prevent cross threading, never force the spark plug to start threading.
3. After the spark plug is seated, tighten with a spark plug wrench to compress the spark plug washer.
4. The spark plug must be securely tightened. An improperly tightened spark plug can become very hot and may damage the engine.

Section 5: Storage

5.1 Long term storage

When not in use, the Grainline grain auger must be safely stored so that it will not fall accidentally. Care should be given to ensure it is stable and does not pose a risk of falling onto a person who is preparing it for use. The ideal location for storage of the grain auger is in an enclosed shed.

Section 6: Specifications

6.1 Transfer Auger Specifications

Specifications	Information
Approximate Capacity	120 tonnes/hour based on wheat
Finish	Grainline Blue 2 pack paint
Engine	Honda GX270 petrol engine
Drive Chain	10B Duplex 32.5 links (P/N: 2-1153)
Top Sprocket & Bush	10B Duplex 15th (P/N: 5-0228) & 1210 1" bore bush (P/N: 5-0204)
Lower Sprocket & Bush	10B Duplex 57th (P/N: 5-0232) & 2517 30mm bore bush (P/N: 5-0222)
Pulley	SPB224-2 9" 2B (P/N: 5-0541) with 2517 1" bore bush (P/N: 5-0223)
Driveline Bearings	P205 Pillar housing with SA205-16 bearing (P/N: 4-0026)
Flight Shaft Bearing	FL206 Flange housing with SB206 30mm bearing (P/N: 4-0019)
Centrifugal Clutch	5HD 89mm x 2AB SW x 1" bore (P/N: 5-0170)
Wheels	14 inch Sunraysia wheel with 184R14C tyre (P/N: 5-0159)
Wheel Hub Assemblies	5 stud Ford pattern with roller bearings (P/N: 4-0106)
Chain Tensioner Roller	LFX Ertalon roller (P/N: 3-0093)
Stop Switch	Emergency stop switch – Normally open (P/N: 5-0339)

6.2 Transfer Auger Dimensions

Side view

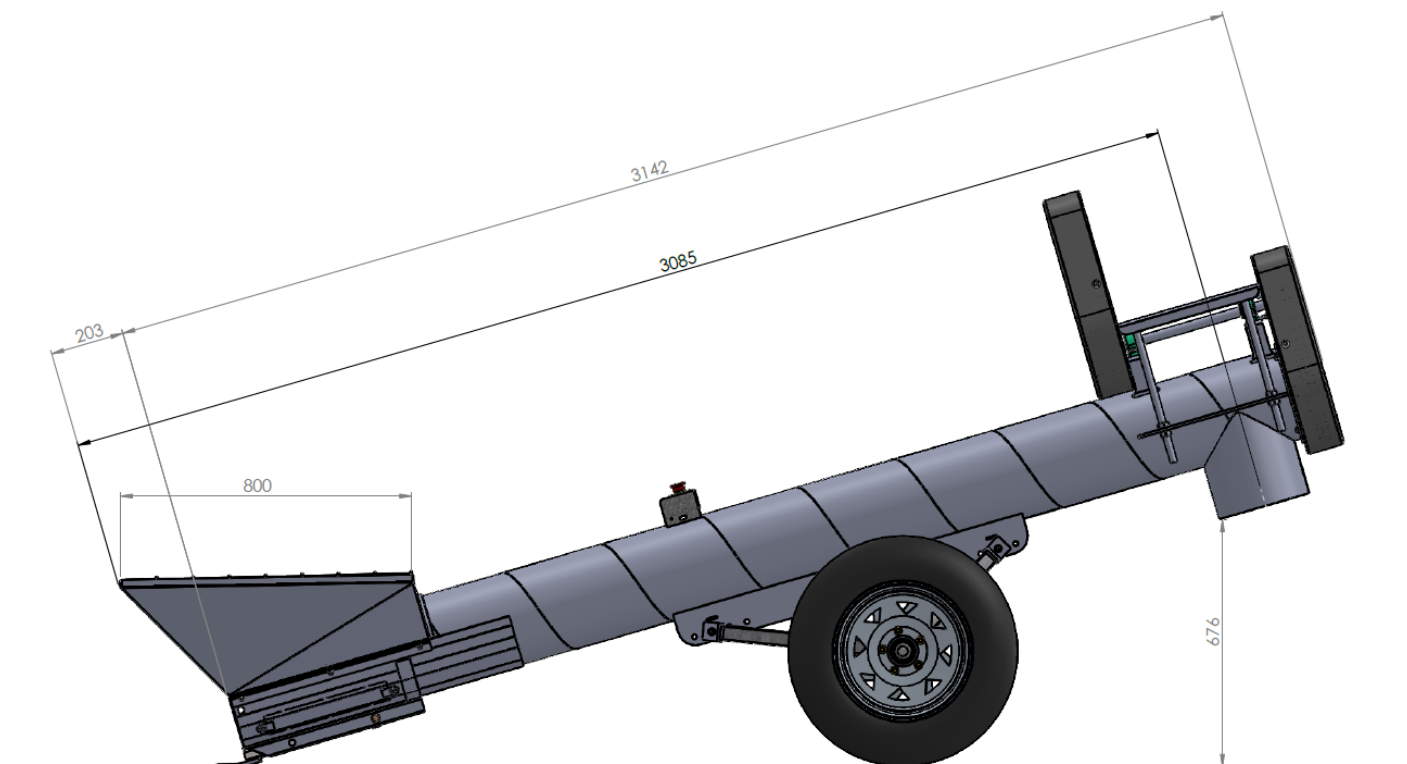

Top View

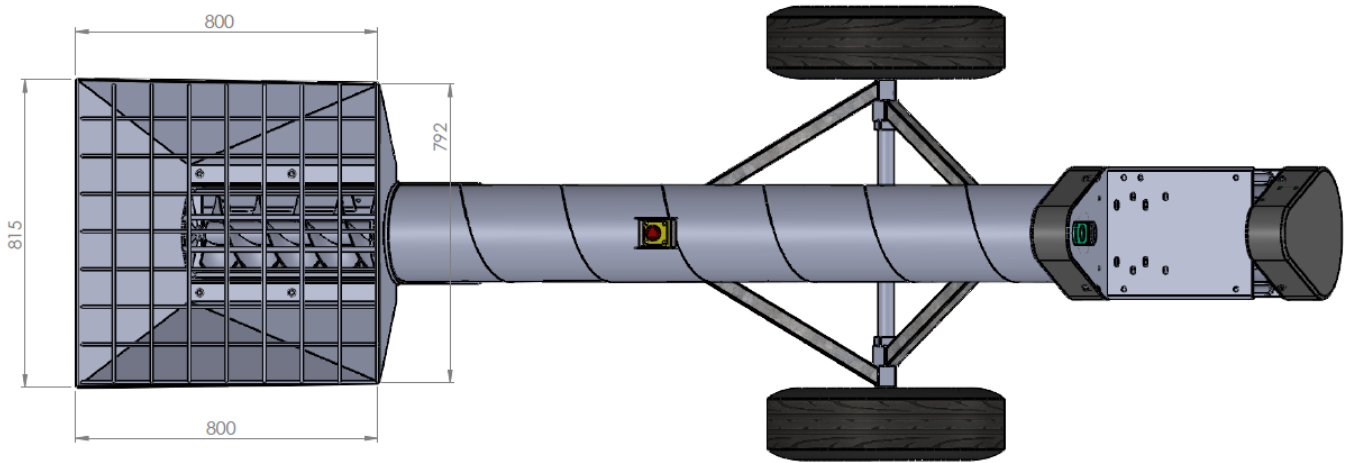

Notes:



1 Hartog Place, East Wagga Wagga NSW 2650, Australia

Phone: 1800 810 498

Email: sales@grainline.com.au

Website: www.grainline.com.au



Scan to request replacement manuals & spare parts.
