



Operators Manual

Transportable Augers

Petrol, Hydraulic, PTO & Electric Models



Contents

Introduction	3
Serial Number Location	3
Disclaimer	3
Induction Sheet for Operators.....	4
Grainline Warranty Registration	5
Grainline Warranty Conditions.....	5

Section 1: Safety Information

1.1 Hazard Labels	6
1.2 General Safety	6
1.3 Intended Use	6
1.4 Correct Usage	6
1.5 Incorrect Usage	7
1.6 Transportation Safety	7
1.7 Safety Decals	8
1.8 Diagram of Decal Placement	12
1.9 Location and Usage of Safety Devices & Guarding	12
1.10 Transportation	13
1.11 Towing procedure.....	13

Section 2: Installation

2.1 Undercarriage Assembly	14
2.2 Third Wheel A Frame Assembly	15
2.3 Top End Assembly for 65ft and 70ft Augers	16

Section 3: Operation

3.1 Before Operation	18
3.2 Initial Running of the Grain Auger	18
3.3 Pre-operation checklist for petrol, PTO, hydraulic and electric augers	19
3.4 Drive System (petrol engine with electric start)	19
3.5 Start up and break in procedure	19
3.6 Third Wheel Operation	20
3.7 Full Load Procedure	21
3.8 Completion and cleanup.....	22
3.9 Hydraulic drive and lift kit operation.....	22

Section 4: Lubrication & Maintenance

4.1 Maintenance	24
4.2 Upper Chain Drive (Petrol, PTO & Electric Models)	26
4.3 Drive Belts (Petrol, Electric & PTO Models)	27
4.4 Belt Tension Unit (Petrol & PTO Models)	27
4.5 Adjusting Belt Tension When Belts Run-on – Petrol Models	28
4.6 Belt Tensioning (Electric Augers)	29
4.7 Hydraulic Drive System (Hydraulic Powered Augers).....	29
4.8 Hydraulic motor drive coupling	29
4.9 Winch Maintenance.....	29
4.10 Winch Cable	29
4.11 Lifting Track, track runner and pulleys.....	30
4.12 Bearings	30

4.13 Fasteners	30
4.14 Wheel hubs	30
4.15 Tyre Pressure	30
4.16 Engine Servicing	30
4.17 Lubrication	30
4.18 Checking engine crankcase oil level	30
4.19 Changing oil and oil filter (if fitted)	31
4.20 Air Cleaner Servicing	31
4.21 Spark Plug Service	32
4.22 Installing Spark Plug	32
4.23 Replacing Oil – Reversible Gearbox	32

Section 5: Storage

5.1 Long Term Storage	33
-----------------------------	----

Section 6: Specifications

6.1 Standard 6 Inch 30-40ft Transportable Augers	33
6.2 Standard 8 Inch 30-56ft Transportable Augers	33
6.3 Standard 10 Inch 30-70ft Transportable Augers	34
6.4 Standard 12 Inch 36-50ft Transportable Augers	34

Grainline Warranty Registration

Please ensure that you complete the warranty registration for your transportable auger as directed below. This will ensure that your details as the owner are accurate and allow a faster response time to any issues that may arise.

To complete your warranty registration please scan the QR code or go to:

www.grainline.com.au/warranty-registration



Grainline Warranty Conditions

Limited 2 year warranty for all products manufactured by Grainline.

What this warranty will cover.

Grainline will at its own discretion, repair or replace without charge any part of our products which may be found defective in material and/or workmanship within 24 months of the original purchase date.

At Grainline's request the customer will make the defective part available for inspection by Grainline or a dealer of Grainline products so cause of the faulty / defective part can be identified for accurate repair.

All parts used and manufactured on Grainline products are covered by this warranty except for the following components, which are covered by their respective manufacturer's warranty.

- Honda Engines 1300 246 632 - poweredby.honda.com.au/Warranty
- Vanguard Engines 1300 274 447 - vanguardengines.com/service-support
- Kohler Engines 02 9830 2305 - epgengines.com.au/contact-EPG-engines
- It is the owner's responsibility to transport defective parts and/or units to their local service dealer who can negotiate a call-out fee at the owner's expense.
- A warranty form must be completed and sent to Grainline and authorisation is needed before a service dealer is able to commence any repairs on Grainline products.

What this warranty will not cover.

- Defects caused by depreciation or damage caused by normal wear, accidents, improper maintenance, improper use and abuse of the product, alterations, or failure to follow the instructions contained in the owner's manual for operation and maintenance.
 - Transport cost for making Grainline products available for inspection and/or repair to and from the place where the warranty work is performed.
-

How to obtain service under this warranty.

Warranty service can be arranged by contacting either your Grainline Dealer or Grainline direct on 1800 810 498. Please have the auger model and serial number available as this will be required by the service technician.

1. Safety Information

The owner is responsible for the safe operation and maintenance of this equipment. Please note that information of special importance has been highlighted in this manual using the below signal words.

1.1 Hazard Labels

DANGER

Indicates an imminently hazardous situation that, if not avoided, will result in serious injury or death.

WARNING

Indicates a hazardous situation that, if not avoided, could result in serious injury or death.

CAUTION

Indicates a hazardous situation that, if not avoided may result in minor or moderate injury.

NOTICE

Indicates a potentially hazardous situation that, if not avoided, may result in property damage

1.2 General Safety

The Grainline grain auger must not be used when the operator is:

- Taking medication that causes drowsiness.
- Under the influence of alcohol or drugs
- Incompetent
- Not aware of the operating procedures

Manufacturers, retailers, owners, and operators all have responsibilities with regards to safety. Be aware of your responsibilities and carry them out. The owner or designated officer is responsible for the safe operation and maintenance of this equipment. The most important part of safe operation is a safety conscious operator who always remembers to:

- Keep children away from grain auger work area.
- Be aware of overhead electrical lines. Electrocution can occur without direct contact.
- Do not operate grain auger with any safety shield, cover or guard removed.
- Keep body, hair, and clothing away from all moving parts.
- Inspect drive belts, drivelines, cables, bolts and nuts and intake area before operating grain auger.
- Replace, repair, tighten and clean out any parts or areas that need attention.
- Keep well away from grain auger intake during operation.
- Petrol engines to be operated in an adequately ventilated area.

1.3 Intended Use

The Grainline Transportable Auger has been designed and manufactured, to assist in the safe and effective transfer of various grain types. Use of the auger in any other way is considered as misuse and is not covered by the warranty.

1.4 Correct Usage

The Grainline auger must be used in accordance with the safety instructions contained within this manual. Only competent personnel who have received proper training and are familiar with the machine should operate and perform any service work on the auger. When the auger is being used hearing protection must be worn, and it is the owner's responsibility to provide the appropriate hearing protection to all others involved in the operation of the auger. When the auger is not in use, it must be immobilized – i.e., turned off and key removed from the power source. Please note, where guards and safety features are removed in this manual it is for illustration purposes only.

1.5 Incorrect Usage

The Grainline auger must not be used for anything other than the intended purpose set out by Grainline.

Incorrect use of the auger includes:

- Using the auger as a hoist or crane.
- Using the auger to transfer grains or materials other than dry, free-flowing food grains.

WARNING: Any modification to the Grainline auger without the approval of Grainline will void all warranty and could result in death or serious injury.



1.6 Transportation Safety



- Check applicable state or territory laws and regulations before transporting.
- Always travel at a safe speed and never exceed 50 kph.
- Never transport the swing away during heavy fog, snow, or heavy rain.
- Fully lower the auger before transporting and only raise when next to a storage facility.
- When towing always attach safety chains and use a suitable towing vehicle with a pin and retainer.
- Empty all grain out of the auger prior to transporting.
- Ensure axles are fully retracted and secured prior to towing.



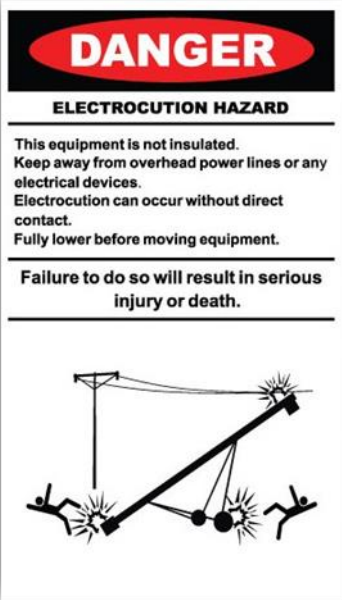

1.7 Safety Decals

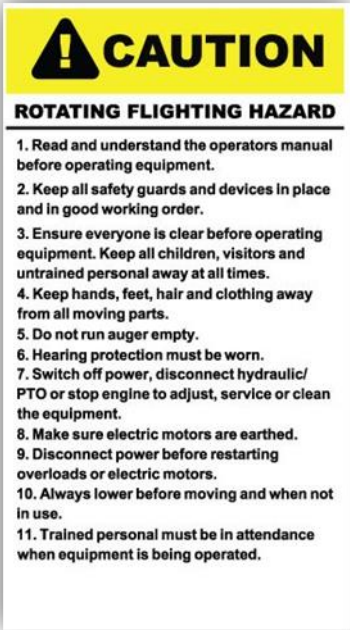



Samples of the safety decals here are those used on the Grainline transportable augers.

WARNING: Regularly read all safety decals that appear on your Grainline auger and replace them if damaged. Failure to do so could result in serious injury or death.

Decal No.	Decal Explanation	Decal Detail
<p>Decal 1.</p>	<p style="text-align: center;">ELECTROCUTION HAZARD</p> <ul style="list-style-type: none"> - When operating or moving keep auger away from overhead power lines and devices. - Fully lower auger before moving. - Electrocutation can occur without direct contact. 	 <p>The decal features a red oval with the word "DANGER" in white. Below it, the text reads "ELECTROCUTION HAZARD". The main body of text states: "This equipment is not insulated. Keep away from overhead power lines or any electrical devices. Electrocutation can occur without direct contact. Fully lower before moving equipment." A horizontal line follows, with the text "Failure to do so will result in serious injury or death." Below this is a black and white illustration of a person being struck by a power line while an auger is positioned nearby.</p>
<p>Decal 2.</p>	<p style="text-align: center;">EXPOSED ROTATING FLIGHTING</p> <ul style="list-style-type: none"> - Keep hands, feet, and clothing away from intake. - Keep guarding in place. 	 <p>The decal features a red oval with the word "DANGER" in white. Below it, the text reads "EXPOSED ROTATING FLIGHTING". The main body of text states: "Keep hands, feet and clothing away from intake. Keep guarding in place and in good working order. If outer guard is required to be removed, an alternative means must be adapted to ensure flighting is guarded to the required standard." A horizontal line follows, with the text "Failure to do so will result in serious injury or death." Below this is a black and white illustration of a person being struck by a rotating auger component.</p>

<p>Decal 3.</p>	<p style="text-align: center;">UPENDING HAZARD</p> <ul style="list-style-type: none"> - Anchor intake end and/or support discharge end to prevent upending. - Intake end must always have downward weight. Do not release until attached to tow bar or resting on ground. - Do not raise intake end above tow bar height. 	 <p style="text-align: center;">DANGER</p> <p style="text-align: center;">UPENDING HAZARD</p> <p>Support discharge end or anchor intake end to prevent upending. Intake end must always have downward weight. Shut supply into intake off slowly to prevent equipment suddenly becoming top heavy. Empty and fully lower before moving equipment.</p> <p style="text-align: center;">Failure to do so will result in serious injury or death.</p>
<p>Decal 4.</p>	<p style="text-align: center;">ROTATING FLIGHTING HAZARD</p> <ul style="list-style-type: none"> - Warns of rotating flighting hazard on the intake of the grain auger. - Sets out the steps to follow for the safe operation of the grain auger. 	 <p style="text-align: center;">CAUTION</p> <p style="text-align: center;">ROTATING FLIGHTING HAZARD</p> <ol style="list-style-type: none"> 1. Read and understand the operators manual before operating equipment. 2. Keep all safety guards and devices in place and in good working order. 3. Ensure everyone is clear before operating equipment. Keep all children, visitors and untrained personal away at all times. 4. Keep hands, feet, hair and clothing away from all moving parts. 5. Do not run auger empty. 6. Hearing protection must be worn. 7. Switch off power, disconnect hydraulic/PTO or stop engine to adjust, service or clean the equipment. 8. Make sure electric motors are earthed. 9. Disconnect power before restarting overloads or electric motors. 10. Always lower before moving and when not in use. 11. Trained personal must be in attendance when equipment is being operated.
<p>Decal 5.</p>	<p style="text-align: center;">ROTATING DRIVE HAZARD</p> <ul style="list-style-type: none"> - Keep guarding in place and in good working order. - Do NOT operate if guarding has been removed. 	 <p style="text-align: center;">DANGER</p> <p style="text-align: center;">ROTATING DRIVE HAZARD</p> <p>Keep guarding in place and in good working order. Do not operate if guarding has been removed.</p> <p style="text-align: center;">Failure to do so will result in serious injury or death.</p>

<p>Decal 6.</p>	<p style="text-align: center;">TRANSPORTING</p> <ul style="list-style-type: none"> - Check state authority regulations before towing on public roads. - Always attach safety chains before towing. - Ensure auger is lowered to transport position. - Maintain tension on winch cable when towing. - Mesh guard may need to be removed to avoid damage to vehicle when turning. 	 <p>CAUTION WHEN TRANSPORTING</p> <p>Check State Authority Regulations before towing on public roads. Always attach safety chains when towing. Ensure auger is lowered to transport position. Maintain tension on winch cable when towing. Mesh guard may need to be removed to avoid damage to vehicle when turning.</p>
<p>Decal 7.</p>	<p style="text-align: center;">READ AND UNDERSTAND OPERATORS' MANUAL</p> <ul style="list-style-type: none"> - Make sure you understand and follow safe operating procedures. - Manual must be always kept with equipment. 	 <p>WARNING READ AND UNDERSTAND OPERATORS' MANUAL BEFORE OPERATING EQUIPMENT</p> <p>Make sure you understand and follow safe operating procedures. Manual must be kept with equipment at all times.</p> <p>Failure to do so may result in serious injury or death.</p>
<p>Decal 8.</p>	<p style="text-align: center;">DO NOT RUN AUGER EMPTY</p> <ul style="list-style-type: none"> - Hearing protection must be worn. - Keep electric motor and leads protected against moisture. 	 <p>WARNING DO NOT RUN AUGER EMPTY</p> <p>Hearing protection must be worn.</p> <p>Keep electric motor and leads protected against damage and moisture.</p> <p>Failure to do so may result in serious injury or death.</p>
<p>Decal 9.</p>	<p style="text-align: center;">WINCH CABLE HAZARD</p> <ul style="list-style-type: none"> - Frequently inspect the entire length of the cable. - Stay clear of cable when equipment is being raised or lowered. - Ensure there is always a minimum of three revolutions of cable around the winch drum. 	 <p>DANGER WINCH CABLE HAZARD</p> <p>Frequently inspect the entire length of cable for damage or fraying. Replace immediately if damage.</p> <p>Keep clear of cable and cable sheaves nip points when equipment is being raised or lowered. Make sure cable sheaves rotate freely when in operation.</p> <p>Ensure that there is at least 3 revolutions of cable around the winch drum at all times.</p> <p>Failure to do so will result in serious injury or death.</p>
<p>Decal 10.</p>	<p style="text-align: center;">GEARBOX SELECTOR</p> <ul style="list-style-type: none"> - Do not move gear selector when belt-tension lever is engaged. 	 <p>FORWARD - NEUTRAL - REVERSE</p> <p>CAUTION DO NOT MOVE GEAR SELECTOR WHEN BELT-TENSION LEVER IS ENGAGED</p>

<p>Decal 11.</p>	<p style="text-align: center;">THIRD WHEEL WIRE ROPES</p> <ul style="list-style-type: none"> - Take notice of cable routing when lifting third wheel. 	
<p>Decal 12.</p>	<p style="text-align: center;">HIGH PRESSURE HYDRAULIC OIL HAZARD</p> <ul style="list-style-type: none"> - Warns of the hazards associated with high pressure hydraulic systems. - Frequently inspect all hoses and replace immediately if damaged. - Ensure pressure is released before disconnecting hoses. 	
<p>Decal 13.</p>	<p style="text-align: center;">INTAKE</p> <ul style="list-style-type: none"> - Ensure nothing is attached to auger intake prior to raising intake end with the third wheel 	
<p>Decal 14.</p>	<p style="text-align: center;">AUGER FLIGHT LEVER</p> <ul style="list-style-type: none"> - Observe directions for belt engagement and disengagement. 	

1.8 Diagram of Decal Placement

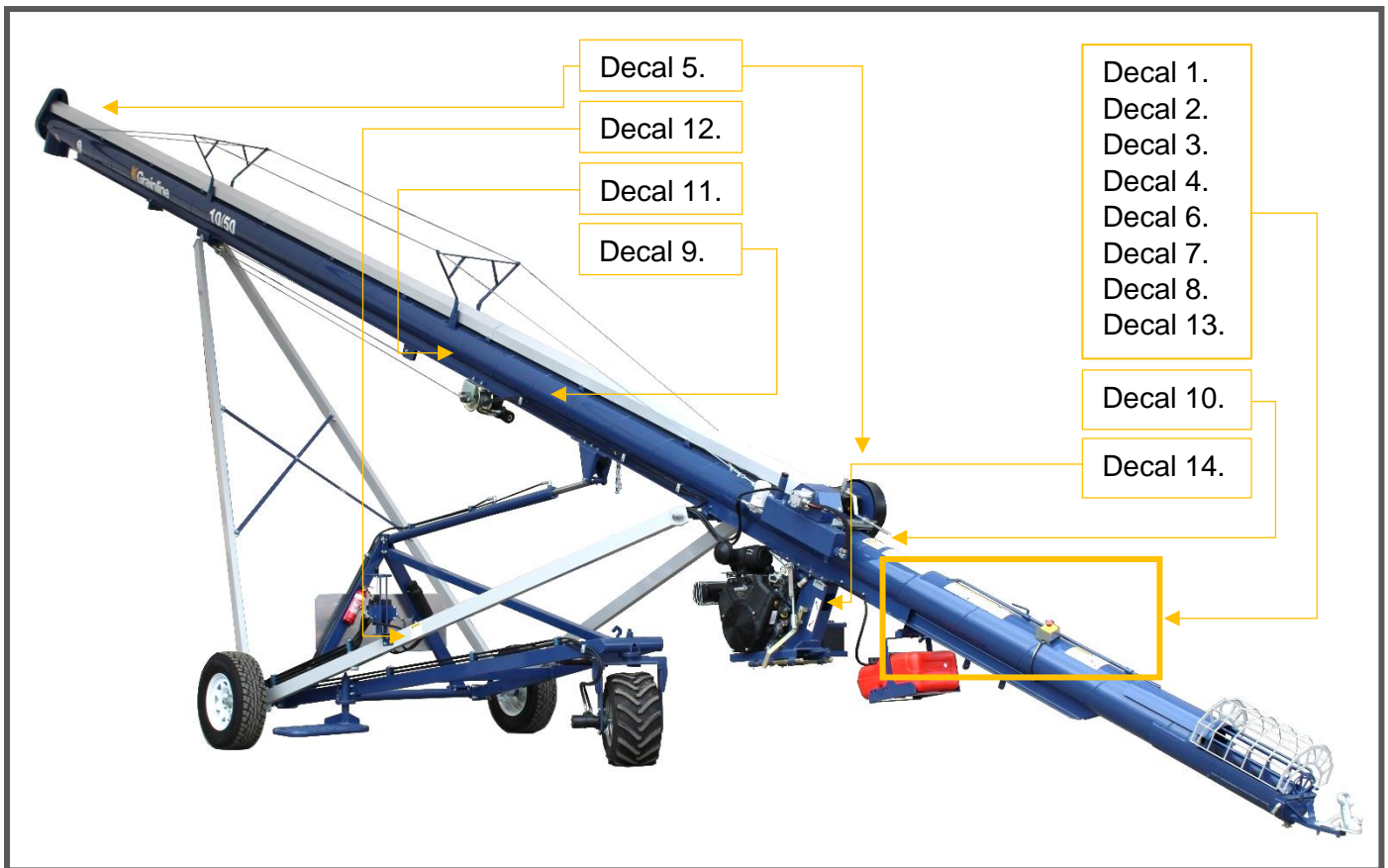

1.9 Location and Usage of Safety Devices & Guarding

Emergency Stop Switch

It is important to check that the emergency stop switch is working correctly prior to every use of the auger. The emergency stop switch is located close to the auger intake to enable the operator to quickly stop the auger in an emergency situation.

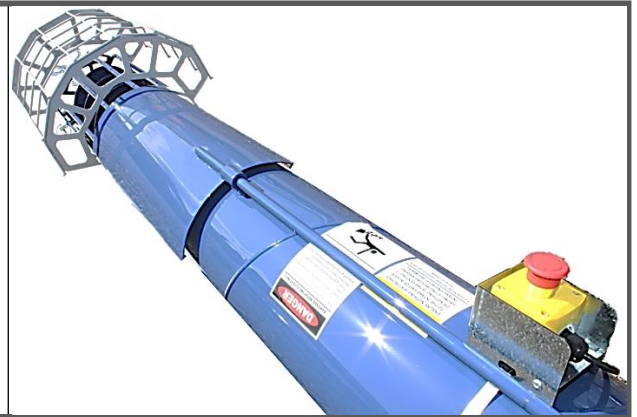

Auger Flying Intake Guard

The auger intake guarding consists of fixed inner bars with a removeable outer guard. Where it is not practical to use the outer guard such as in a silo boot, the outer guard can be removed from the auger. When the outer guard is removed it is important to ensure that no one is exposed to the auger flying during operation. The outer guard must be reinstalled on the auger as soon as the task is complete.

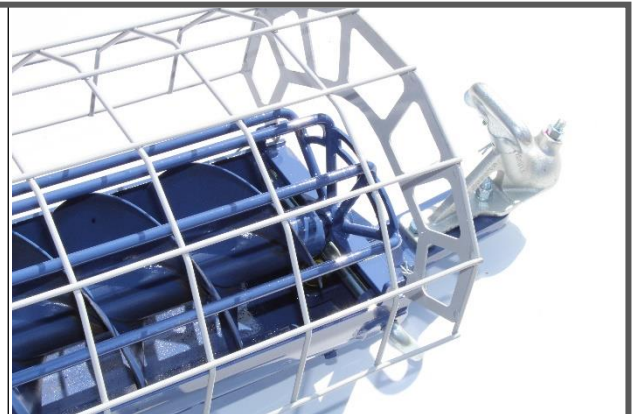

Belt, Shaft and Chain Guards

All drive and motion parts including drive shafts, couplings, drive chains and drive belts are covered by guards and shields to ensure maximum operator safety. If any guards or shields are removed for service and maintenance, they must be reinstated immediately after work is complete.



1.10 Transportation

The Grainline transportable augers have been designed and engineered to allow them to be safely transported on a public road or property.

- Check applicable state laws and regulations before transporting.
- Always travel at a safe speed.
- Never transport augers during heavy fog, snow or heavy rain.
- Fully lower the auger before transporting.
- When towing always attach safety chains and use an approved tow coupling.
- Empty all grain/seed out of the auger before transporting.

1.11 Towing Procedure

- Place auger in its lowest position and ensure the slide runner connected to the auger reach arms is against the slide runner stopper.
- Equip the tow vehicle and auger with any flashing beacons, signs and flags as required by your states road authority.
- Connect the auger to the tow vehicle, ensuring that the tow coupling is fully secured, and safety chains are fitted.
- Raise third wheel assembly if fitted and secure with transport safety chain.
- Remove keys from the auger ignition if fitted with a petrol engine.
- When towing be alert to overhead powerlines and structures. Use caution when turning and cornering.
- Stop after 20 kilometres and check the following: Wheel bearings for overheating or excessive play. Safety chains, tow coupling and visually check all fasteners.

NOTICE: Always check tyre pressure before towing, recommended pressure for towing is 15 psi. It is recommended that mesh intake guard is removed to prevent possible damage to the guard and tow vehicle when turning sharply.

Section 2: Installation

2.1 Undercarriage Assembly

Safe operating procedure

- Assemble the grain auger on a level surface.
- Use approved slings with a working load limit of at least 2 tonne to raise the augers.
- Use the correct tools.
- Assembly only to be done by competent persons.

Assembly

- Support discharge end of the auger with suitable lifting equipment and raise approximately 2 metres off the ground.
- Fit the slide runner to the slide track running along the underside of grain auger tubing.
- Place two axle support stands in general area where axle will be located.
- Place axle on two support stands approx. 300mm above ground height. (See Image.1)
- Install lower arms onto each end of axle and bolt on retaining clamps. If auger has third wheel winch option, make sure arm with winch mount is on correct side and facing upwards. Bolt lower arms to trunion bolt and secure with nyloc nuts. Do not fully tighten nuts as arms are required to pivot on the trunion bolt. (See Image.2)
- Place upper reach arms onto axle, making sure any cross-brace lugs and mount bushes are on the right side and bolt on retaining clamps. Raise arms and bolt to the slide runner,
- Raise auger up to allow fitment of slide runner stopper.
- Bolt on slide runner stopper using the supplied bolts and lock nuts.
- Slide wheel assemblies into main axle and secure with bolts and nyloc nuts.
- Remove axle support stands and lifting equipment supporting barrel.

CAUTION: If the auger does not have an engine or motor fitted a counterweight will need to be temporarily fitted to intake end of auger to prevent possible upending.

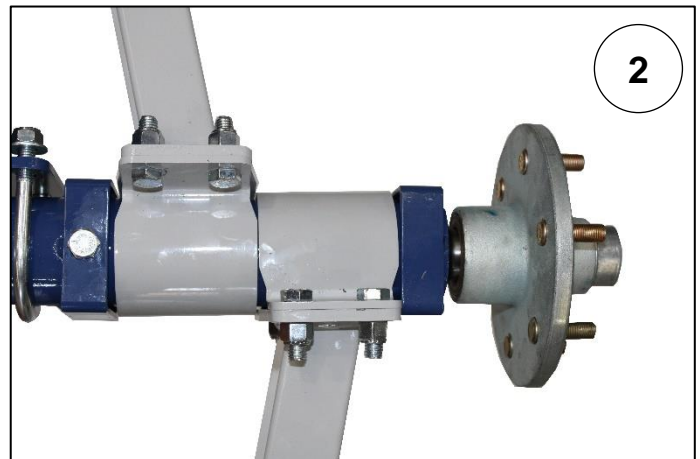

2.2 Third Wheel A Frame Assembly

Assembly

- Bolt A frame to axle using supplied U bolts and nyloc nuts.
- Bolt V post to plates on axle with supplied bolts and nyloc nuts.
- Connect cross brace to top of V post using supplied pins, then connect to A frame using pin supplied.
- If Auger has a hydraulic third wheel lift ram, using pin supplied connect it to the top of the V post then connect to brackets below auger barrel and connect hydraulic hoses.
- If auger has a manual winch, connect winch, pulleys and cable assembly as shown in the drawings below.
- Install third wheel and fork assembly and if Hydraulic drive, connect steering ram and hydraulic hoses.
- If auger has a hydraulic drive and lift kit, please refer to separate installation manual for detailed information.

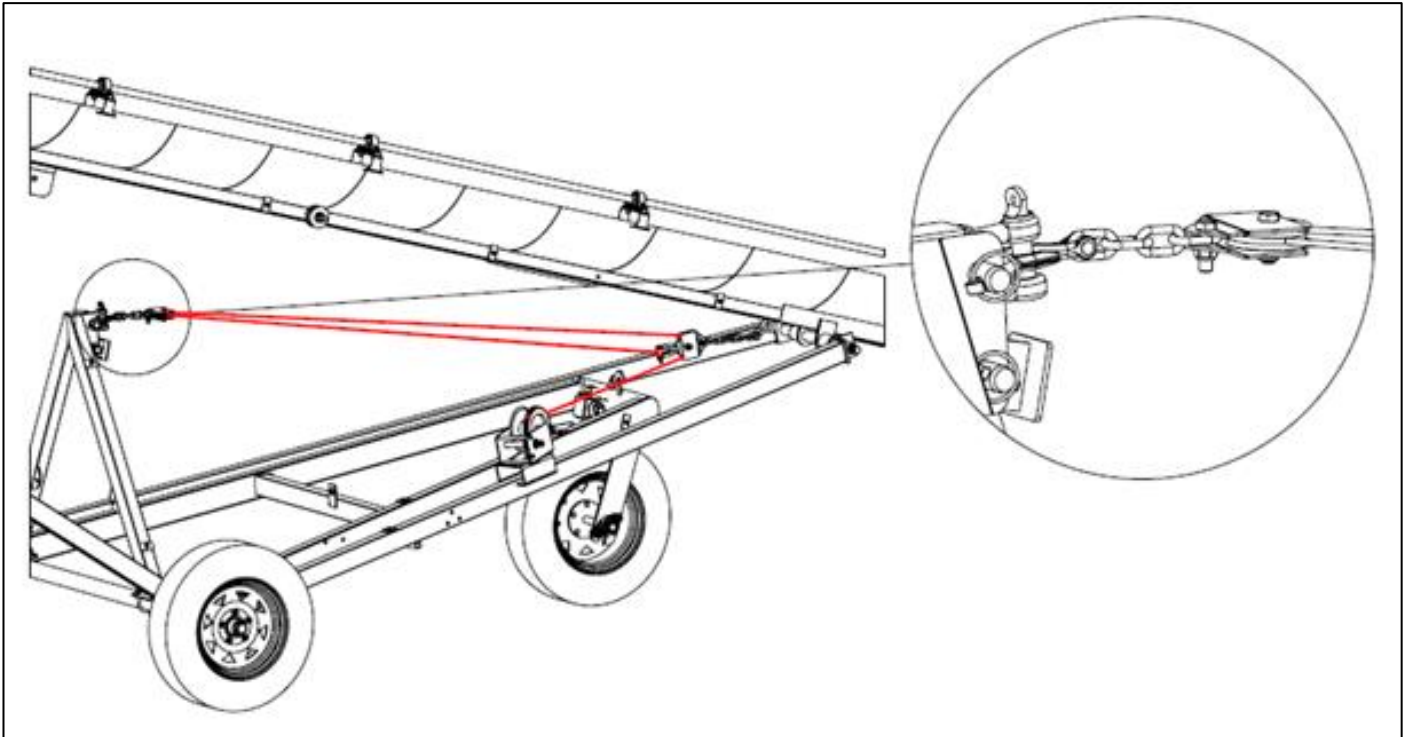

2.3 Top End Assembly for 65ft and 70ft Augers

Due to road transport regulations the top end of the 65ft and 70ft augers need to be folded back when being towed on a public road. This will ensure that the auger length is within the legal transporting length.

Assembly Procedure

- Support folded section of barrel with a forklift or similar and remove clevis pin from transport pin as shown in the diagram.
- Lower folded section of barrel until hanging vertically.
- Using a sling wrap it around the auger barrel between the outlet spigot and angle support under the barrel. Attach sling to a forklift or lifting device and raise folded end section of auger until both hinge plates meet. Bolt the hinge together using the supplied $\frac{3}{4}$ inch x $2\frac{1}{2}$ inch bolts and nyloc nuts. Ensure that the bolts are fully fastened then the supportive sling can be removed from the top of the barrel.
- Open the trap doors on the sides of the barrel to allow access to the flight joining bolt.
- Insert a pry bar or similar into the auger intake end to raise the flighting up until the bolt holes on the flighting centre pipe align. Use top drive shaft to rotate flighting to align bolt hole. A pry bar with a pointed end will help to align the hole perfectly to allow the bolt to be easily inserted.
- Insert the $\frac{1}{2}$ inch x 4 inch long high tensile bolt and secure with the nyloc nut and close the access trapdoors ensuring they are properly latched.
- Using the supplied short section of 10B duplex chain, connect the two sprockets on the top drive shaft and fit chain joiner link.
- Install shaft cover section over sprockets and secure with supplied Tek screws.
- If the auger is a 70ft long model, proceed with connecting the secondary truss cables to the end of the auger and secure with supplied clamps.
- Tension cables using supplied turnbuckles until no sag is present in the truss cables.

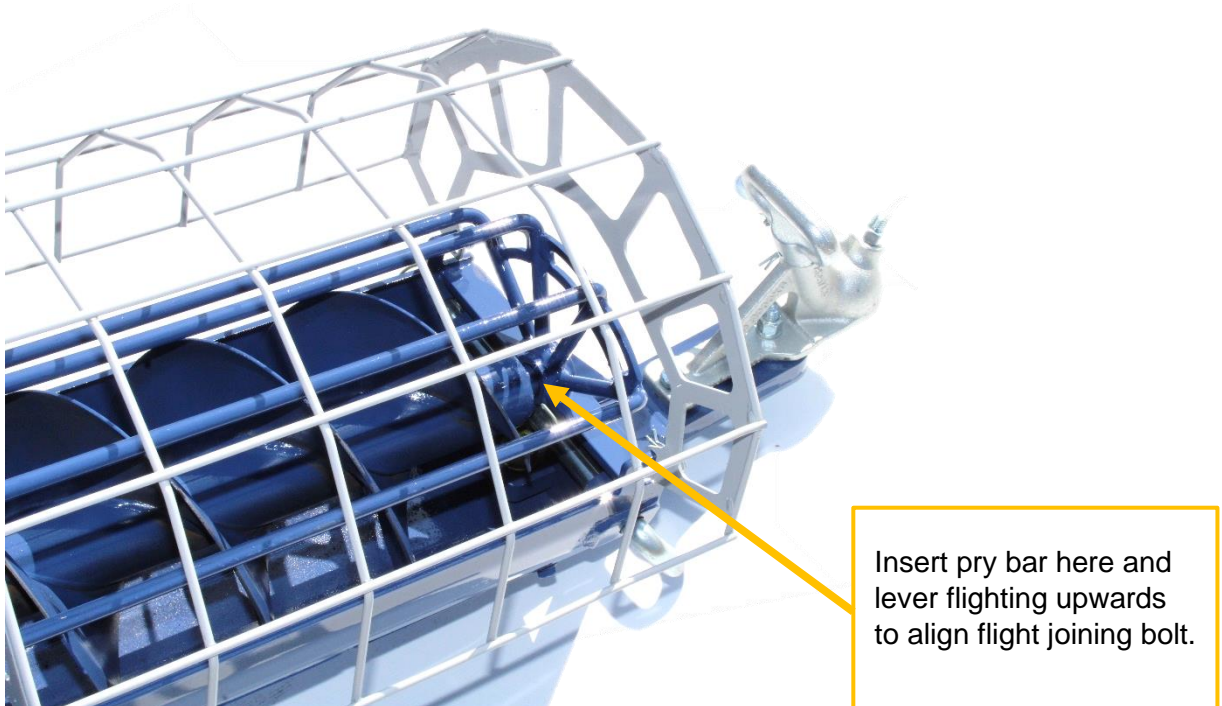

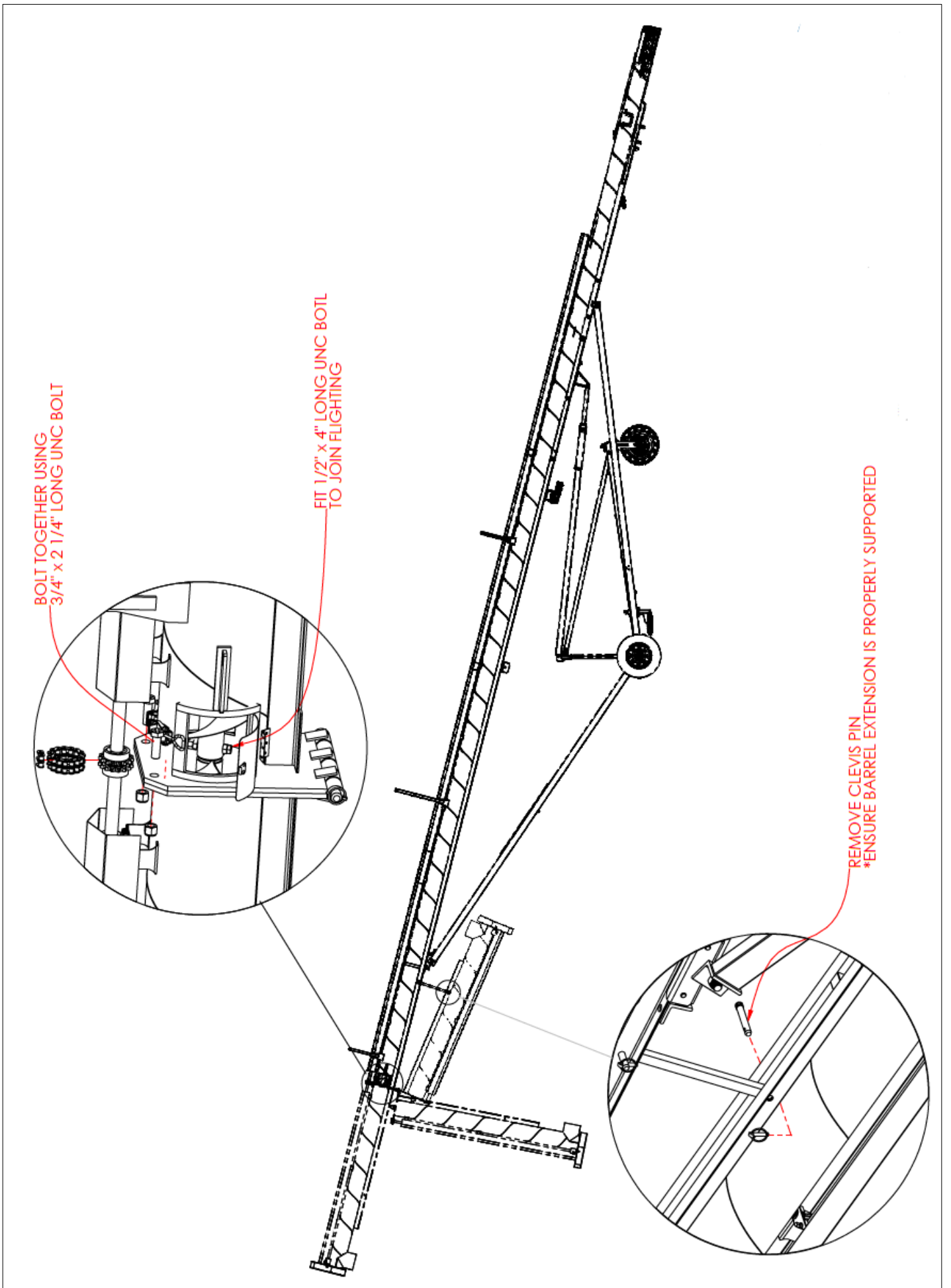

Section 3: Operation

3.1 Before operation

Before moving the grain auger into position for operation, the following pre-operation check must be done.

- Visually check all nuts and bolts.
- Ensure that there are no obstructions in the intake.
- Check winch cables for damage.
- Check for oil leaks on hydraulic and self propelled augers.

DANGER: Electrocution hazard. When operating an auger near overhead power lines, it is essential that there is a clearance of 6 metres for conductors carrying between 133kV and 330kV and 8 metres for conductors carrying over 330kV. These clearances must allow for sagging of the conductor due to their weight or wind.

WARNING: Anchoring and support of the auger during operation is necessary. When the lower half of the auger becomes empty, the grain moving to the top transfers the weight balance to the upper end of the auger, which can cause up-ending. Do not leave auger in the raised position overnight or in high wind or when not in use.

Placement procedure

- Ensure the grain auger wheels are always on level ground.
- Move the auger to its working position and raise it to the required height.
- Chock wheels on both sides.

3.2 Initial running of the grain auger

Safe operating procedure

- Ensure that the work area is clear of unauthorised personal.
- Be ready to shut down the engine or power source in case of an emergency, abnormal noise or excessive vibration for example.
- Ensure the grain auger intake is not obstructed.

Auger Startup

- Ensure the belt tension lever is in the disengaged position. Start the tractor at the lowest possible RPM, once started increase speed to $\frac{3}{4}$ throttle. For hydraulic drive augers connect hydraulic hoses from the grain auger to the hydraulic outlets.
- Slowly move the belt tension lever to the engaged position, as the belts begin to tension the flighting will start to turn, be alert to any abnormal noises or vibrations. For hydraulic augers open the control valve located on the auger. Once the grain auger is running smoothly continue to push the lever to the over centre position against the stop.
- Listen for undue noise, vibration or belt slippage and be prepared to stop the tractor immediately.
- If there is no undue noise and vibration, run the grain auger for a further 15 seconds to check if the auger is running correctly.
- An empty grain auger will always run with greater noise and vibration levels. Once grain starts flowing through the grain auger the noise and vibration will decrease.

3.3 Pre-operation checklist for petrol, PTO, hydraulic and electric augers.

Efficient operation of the grain auger requires that competent operators follow a checklist and be familiar before each start up and demands that safety precautions be observed at all times. To do otherwise is endangering life and limb and is a misuse of equipment.

Before operating the auger for the first time and each subsequent time, the operator must follow a checklist and be familiar with all facets of moving grain with an auger.

Checklist

- All safety guards and shields are in place and secure.
- Winch cable is not frayed or damaged and clamps are secure.
- Drive belts are not frayed and are properly adjusted. (Petrol, PTO and electric augers).
- Drive train and sprockets are in line and correctly tensioned.
- All fasteners are tight or properly adjusted.
- Winch is in suitable working order.
- Slide track stop is in position and secure.
- Wheel bearings are correctly adjusted.
- Auger wheels are properly chocked.
- PTO system is aligned. (PTO powered augers)
- Hydraulic lines are in good working order. (self-propelled & hydraulic augers)
- Auger is a safe distance from power lines.
- Hearing protection is worn.

NOTICE: Correct operation of the grain auger requires pre-inspection of the drive system, operator knowledge on how to shut down the system and general monitoring of the system during operation. In the case of an emergency shutdown with PTO powered augers, the operator must be fully conversant with all controls and shutdown procedures.

3.4 Drive system (petrol engine with electric start)

Before starting the engine ensure:

- Petrol tank is properly closed.
- Oil level is correct.
- Area around auger is properly ventilated.
- Pulleys are aligned and secure.
- Battery cables are suitably connected.
- Battery clamp is in place.
- Follow engine manufactures instructions according to their operator's manual.

NOTICE: In the case of an emergency shutdown, the operator of the grain auger must be fully conversant with all engine controls and shut down procedures.

3.5 Start up and break in procedure

Safe operating procedure

- Ensure you have completed the pre-operation checklist.
- Wear hearing protection.

Procedure

- If everything is satisfactory, prepare for a 15 minute operation at half speed, followed by a 15 minute operation at three quarters speed.
- Start the auger and run at half throttle for 15 minutes, listening for undue noise and vibration. If grain auger functions normally, increase the speed to $\frac{3}{4}$ for 15 minutes.
- After completion of the initial 30 minute run, slow auger down and run until empty, then shut down engine.
- Conduct a complete inspection of the grain auger, referring to the pre operation check list. After initial startup and inspection, the grain auger should be shut down and inspected at least three times during the first ten hours of operation.
- Once the grain auger has been run in, the pre-operation checklist should be part of the daily routine before operating the grain auger.

3.6 Third wheel operation

Safe operating procedure

- Ensure persons operating the third wheel are competent.
- Check for frayed or worn cables.

Procedure

- When not being used or during transport the third wheel is held up and away by the winch cable. This is done by having the cable hook set at position 'B' with the cable looping over the cable guide.
- To use the third wheel, lower it to the ground, and relocate the winch hook to position 'A'.
- Chock both main wheels, then slowly begin to winch the auger until the intake clears the ground and the auger weight is supported by the third wheel and the main wheels. Remove wheel chocks and carefully push auger to desired location.
- When relocated, lower grain auger until the weight is fully removed from the third wheel. Place cable in position 'B' and raise third wheel up and clear.

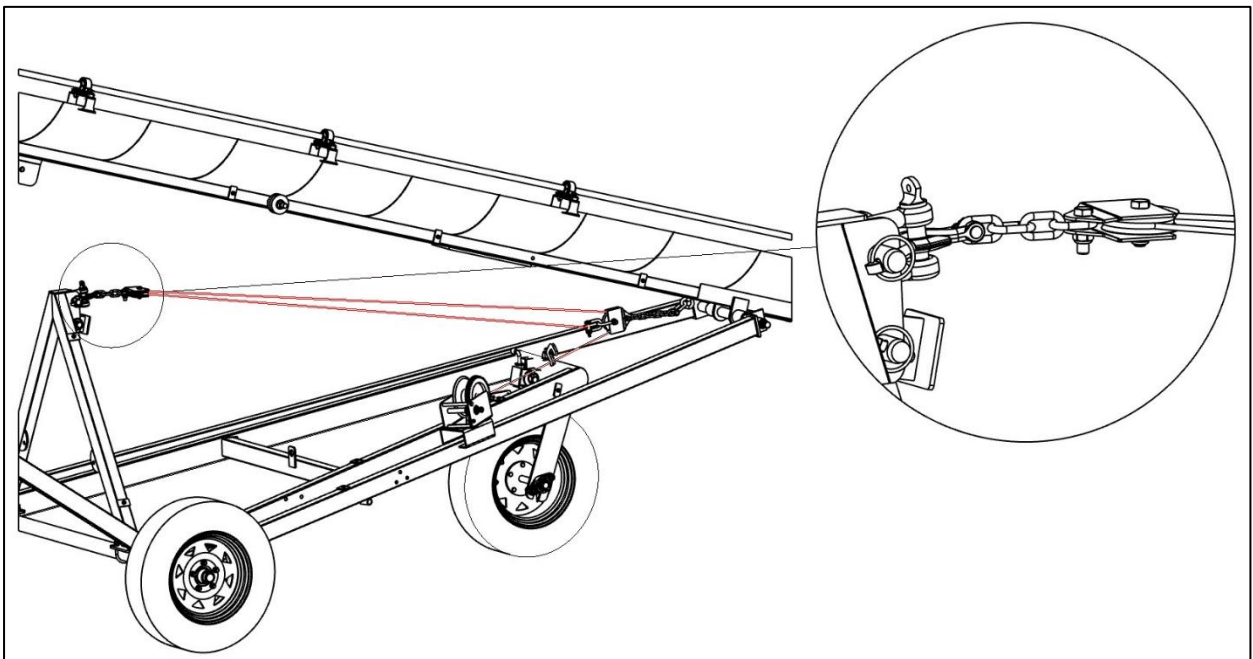

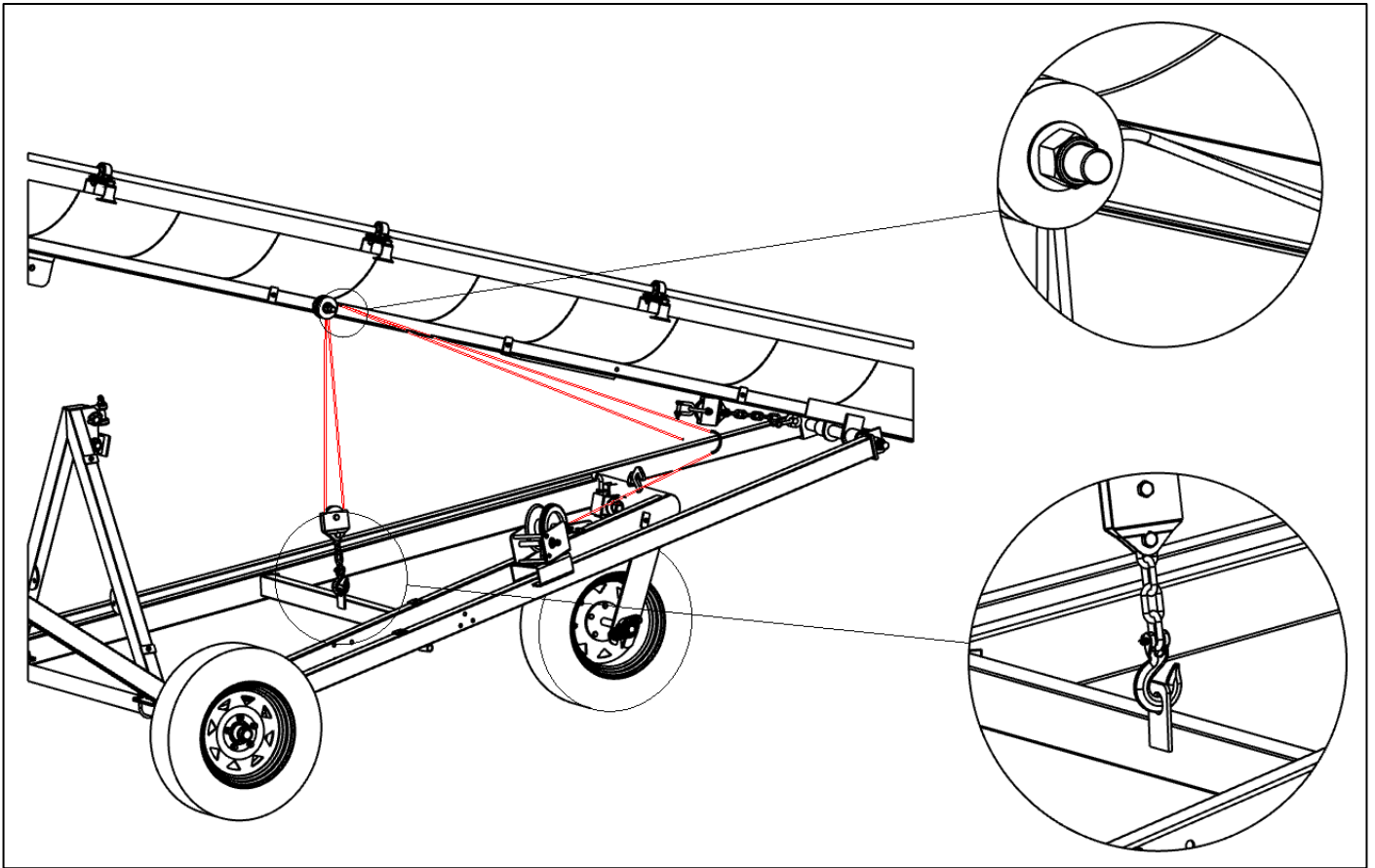

CAUTION: Chock wheels to prevent auger from unexpectedly moving when weight is supported by the third and main wheels. Extra care should be taken on sloped or uneven ground. Care should be taken when pushing auger, avoid overhead obstacles, uneven ground, and ground obstacles.

3.7 Full load procedure

Safe operating procedures

- Ensure auger is anchored to prevent upending.
- Do not repair, clean, or make adjustments to the auger while it is in operation.
- Be aware of entanglement on PTO powered augers.

Procedure

- When operating the auger, always work with a second person in a position to monitor the operation and initiate a shut down in the case of an emergency.
- Monitor the auger during the actual operation for abnormal noises and vibrations.
- Adjust auger choke to suit the augers capacity and power.

Normal shutdown

- Near the end of a load, shut off grain supply if necessary, then decrease the speed of the auger until it is empty of all grain.
- Stop the auger only when it is empty.

3.8 Completion and cleanup

Safe operating procedure;

- Do not leave auger in the raised position.
- Be aware of overhead power lines before moving.

Procedure

- At the completion of an operation, the auger should be moved to a storage area.
- Ensure auger is completely empty of grain.
- Clean entire work area.
- Remove all wheel chocks and store them out of the way.
- Move the auger out of the working position and lower it down.

3.9 Hydraulic drive and lift kit operation

Safe operating procedure;

- Hydraulic drive and lift system only to be operated by qualified personal.
- Check all hoses and fittings before operation.
- Fully understand the controls and their functions before operation.
- Be aware of overhead hazards.

Drive wheel operation

- With the gearbox lever in the neutral position and the belts disengaged, start the engine, and run at low throttle.
- If everything is running smoothly, engage the belt tension lever. This will start the hydraulic pump which operates the hydraulic drive and lift system.
- Raise the foot of the auger off the ground.
- With your hand resting on the ring around the joystick controls, smoothly push the joystick forward. The grain auger will start to move forward. To reverse, slowly back the lever off and pull it smoothly backwards.
- To steer the grain auger, slowly move the joystick left or right.

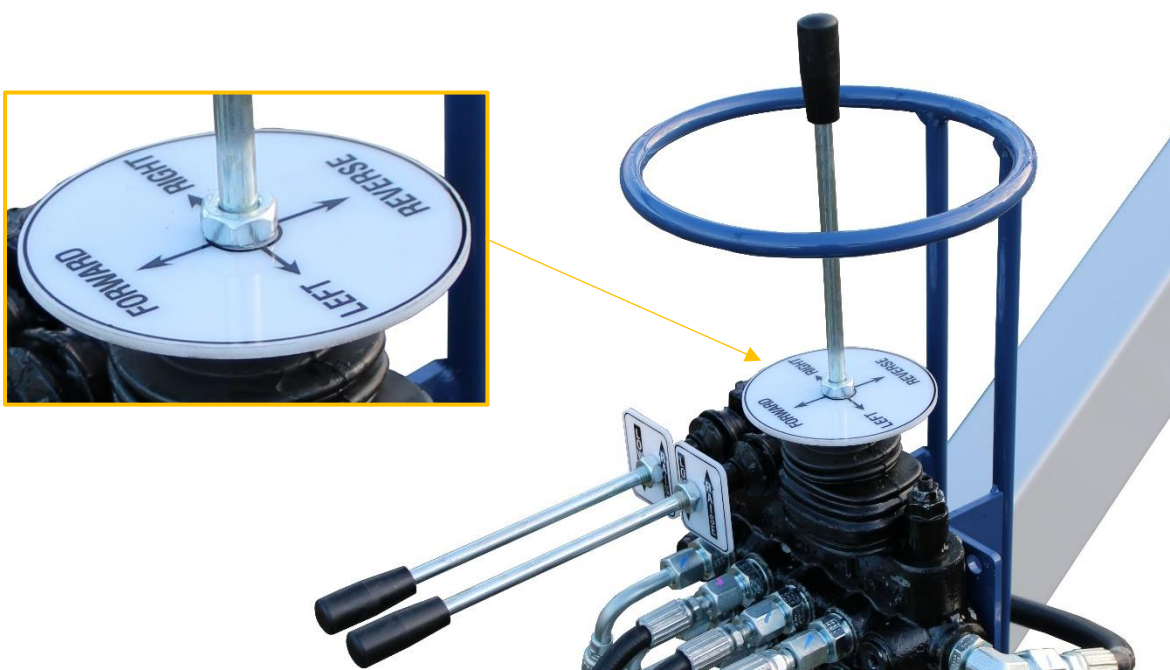

Hydraulic winch & third wheel lift ram operation

- To raise the outlet end of the auger up, pull the outer horizontal control lever upward to engage the hydraulic lift winch and push down to lower the auger.
- To raise the inlet end of the auger up, pull the inner horizontal control lever upward to engage the third wheel lift ram and push down to lower.

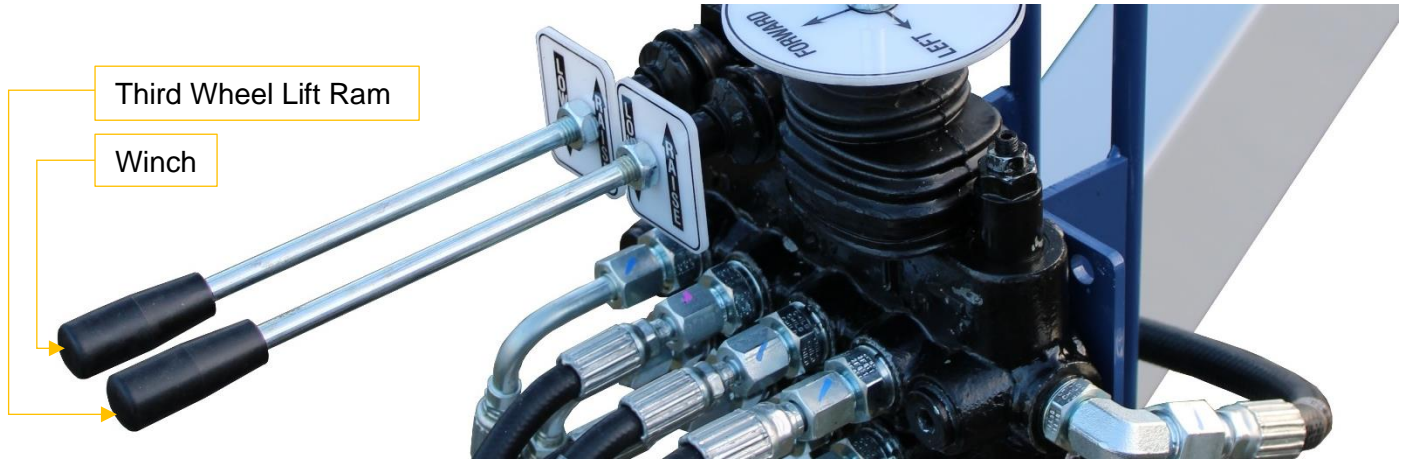

Drive Wheel



Third Wheel Lift Ram



Lift Winch



Section 4: Lubrication & Maintenance

4.1 Maintenance

The auger must be inspected regularly to ensure it is functioning correctly. All problems identified must be rectified prior to use. All safety features must be maintained to ensure they are functioning as intended. Where parts or components require replacing, replacements must be identical or equivalent to the original parts and components. Proper maintenance on the grain auger means a longer life for the machine and more efficient and safer operation.

Safe operating procedure;

- When performing maintenance with an auger, chock the wheels and take precautions to prevent the auger from upending.
- Before attempting to service the engine, remove the ignition key and disconnect the spark plug lead.
- Wear the correct personal protective equipment.

Maintenance Chart - Recommended Service Intervals - Petrol Engines

Service Item	Daily	8hrs	16hrs	24hrs	32hrs	50hrs	Annually
Check engine oil level	Yes						
Check guards and shields	Yes						
Check winch cable	Yes						
Check winch	Yes						
Check drive belts	Yes						
Check slide track stop	Yes						
Service upper drive train		Yes					
Check drive belt tension			Yes				
Check tyre pressure			Yes				
Check battery electrolyte level			Yes				
Service air filter element *				Yes			
Lubricate belt lever joints				Yes			
Lubricate winch					Yes		
Lubricate track slide rollers					Yes		
Tighten bolts & nuts					Yes		
Check bearings					Yes		
Change engine oil **						Yes	Yes
Replace air filter element *						Yes	Yes
Service fuel filter							Yes
Service battery							Yes
Grease wheel hub bearings							Yes
Service spark plugs							Yes
Service spark arrester							Yes

* More often in extremely dusty/dirty conditions

** Change engine crankcase oil on new engine after first 8 hours of break-in operation.

Maintenance Chart - Recommended Service Intervals - PTO Powered

Service Item	Daily	8hrs	16hrs	24hrs	32hrs	Annually
Check Guards And Shields	Yellow					
Check Winch Cable	Yellow					
Check Winch	Yellow					
Check Drive Belts	Yellow					
Check Slide Track Stop	Yellow					
Service Upper Drive Train		Yellow				
Check Drive Belt Tension			Yellow			
Grease Bearing Mount Bearings					Yellow	
Grease PTO Unit Universal Joints			Yellow			
Check Tyre Pressure			Yellow			
Lubricate Belt Lever Joints				Yellow		
Lubricate Winch				Yellow		
Lubricate Track Slide Rollers					Yellow	
Tighten Bolts and Nuts					Yellow	
Check Bearings					Yellow	
Grease Wheel Hub Bearings						Yellow

Maintenance Chart - Recommended Service Intervals - Hydraulic Powered

Service Item	Daily	8hrs	16hrs	36hrs	Annually
Check Guards and Shields	Yellow				
Check Winch Cable	Yellow				
Check Winch	Yellow				
Check Slide Track Stop	Yellow				
Check Hoses and Fittings	Yellow				
Grease And Inspect Coupling		Yellow			
Check Tyre Pressure			Yellow		
Lubricate Winch				Yellow	
Lubricate Track Slide Rollers				Yellow	
Tighten Bolts and Nuts				Yellow	
Check Bearings				Yellow	
Grease Wheel Hub Bearings					Yellow

Maintenance Chart - Recommended Service Intervals - Electric Augers

Service Item	Daily	8hrs	16hrs	24hrs	32hrs	Annually
Check Guards And Shields	Yellow					
Check Winch Cable	Yellow					
Check Winch	Yellow					
Check Drive Belts	Yellow					
Check Slide Track Stop	Yellow					
Service Upper Drive Train		Yellow				
Check Drive Belt Tension			Yellow			
Check Tyre Pressure			Yellow			
Lubricate Winch				Yellow		
Lubricate Track Slide Rollers					Yellow	
Tighten Bolts And Nuts					Yellow	
Check Bearings					Yellow	
Grease Wheel Hub Bearings						Yellow
Check Electrical Lead	Yellow					

WARNING: Poor maintenance not only causes costly breakdowns but can result in serious injury or death.

4.2 Upper chain drive (petrol, PTO & electric models)

- Keep chain well lubricated at all times. A layer of lubricant will prevent the chain from seizing between seasons.
- Check chain deflection, maintain 6-12mm of free movement at all times. Adjust chain free movement by loosening the lock nuts of the top bearing and adjusting the bolts to obtain the correct free movement, screw bolt down to increase free movement or out to decrease movement.

Adjuster Bearing & Top Chain Drive

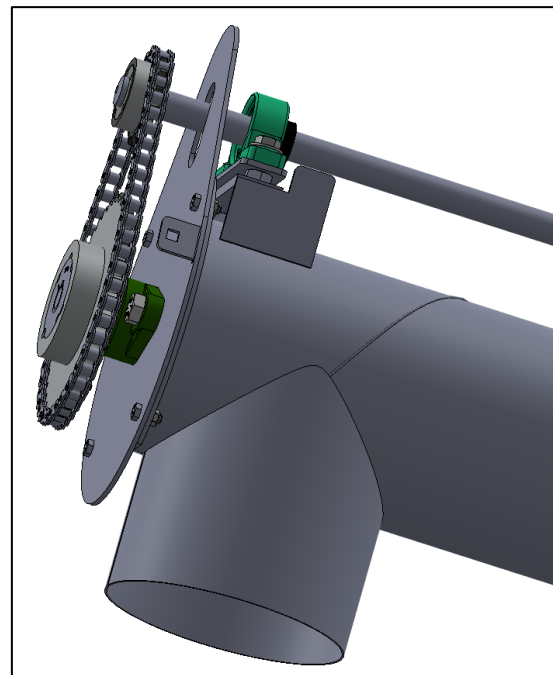
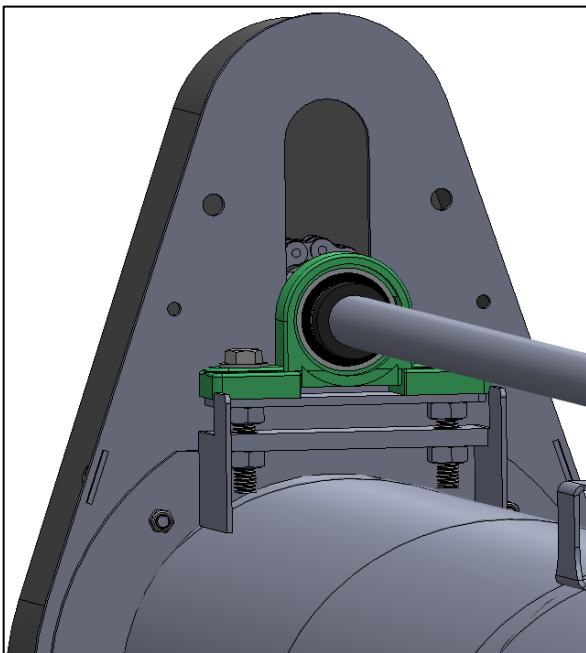

4.3 Drive belts (petrol, electric & PTO models)

After the normal initial belt stretch the belts will settle in and require checking, and if needed, adjusting every 16 hours.

NOTICE: Replace belts if frayed or damaged. The correct operating belt tension is the lowest tension at which the belts will not slip under peak load conditions.

Belt replacement procedure

1. Ensure engine is off and isolated by removing ignition key.
2. Remove belt guard.
3. Slacken belts by lifting the belt tension lever.
4. Remove and replace the damaged belts.
5. Replace belt guard.

DANGER: Always replace belt guard after checking or fitting drive belts.

4.4 Belt tension unit (petrol & PTO models)

- Check for excessive wear of all the bushes and shafts.
- Grease all bushes and shafts.
- Rotate tension pulley & anti flap roller to check bearings, replace if binding occurs.
- Tighten all bolts and nuts.
- Ensure correct operation of engaging and disengaging VEE belt drive to auger.
- Check for excessive wear to pulleys, replace if necessary.
- Check tension spring for weakness, replace if required.

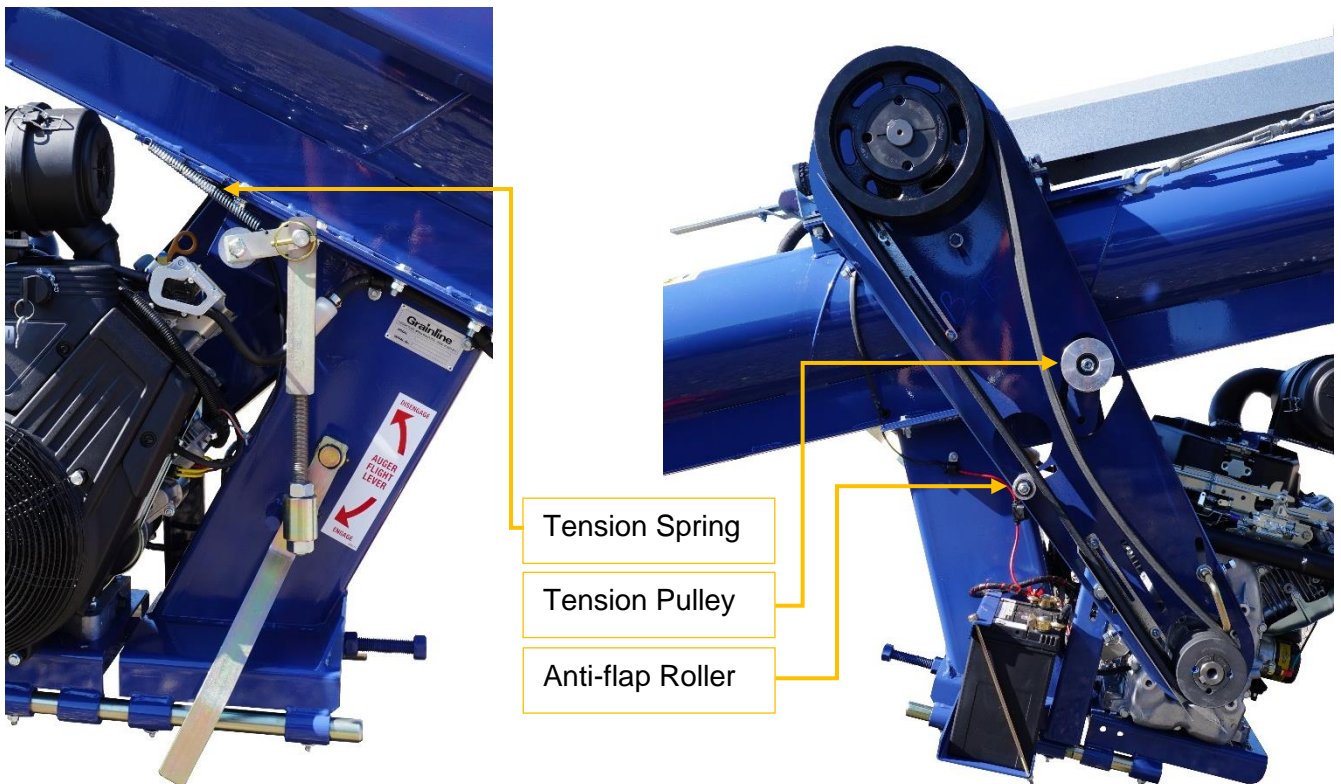

4.5 Adjusting Belt Tension When Belts Run-on - Petrol Models

1. Ensure belt tension lever is disengaged and start engine with throttle at idle.
2. If belts are running on proceed with the following steps.
3. Stop engine, remove key, remove belt guard, and check C shaped bracket as shown in figure 1 below. Ensure that the bracket is set with a space of 6mm between the bracket and belts when the belts are tensioned. See below in figure 2.
4. Adjust bracket if required and replace belt guard.
5. Start engine with throttle at idle and belt tension lever disengaged. If belts continue to run on, proceed with the following steps.
6. With engine still running at idle and belts disengaged, locate the lock nut for the belt tension rod as shown in figure 3.
7. Loosen nut to allow adjustments to tensioner rod, then using a spanner wind the tensioner rod anti-clockwise in quarter turn increments until the belts stop running on.
8. Tighten lock nut and belt tensioner should now function correctly.

Figure 1.

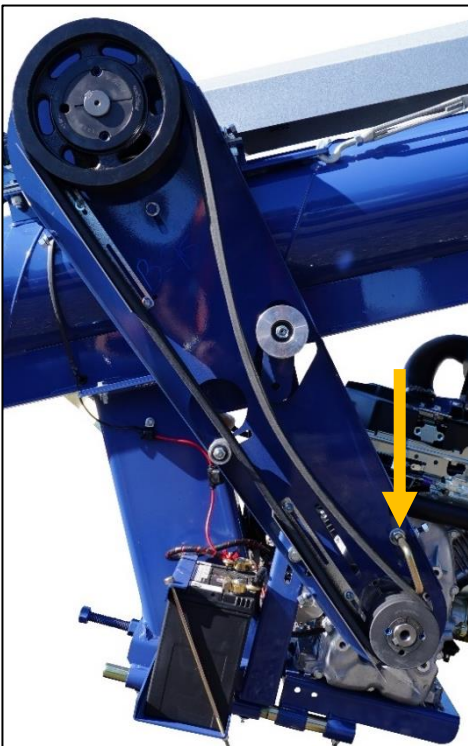

Figure 2.

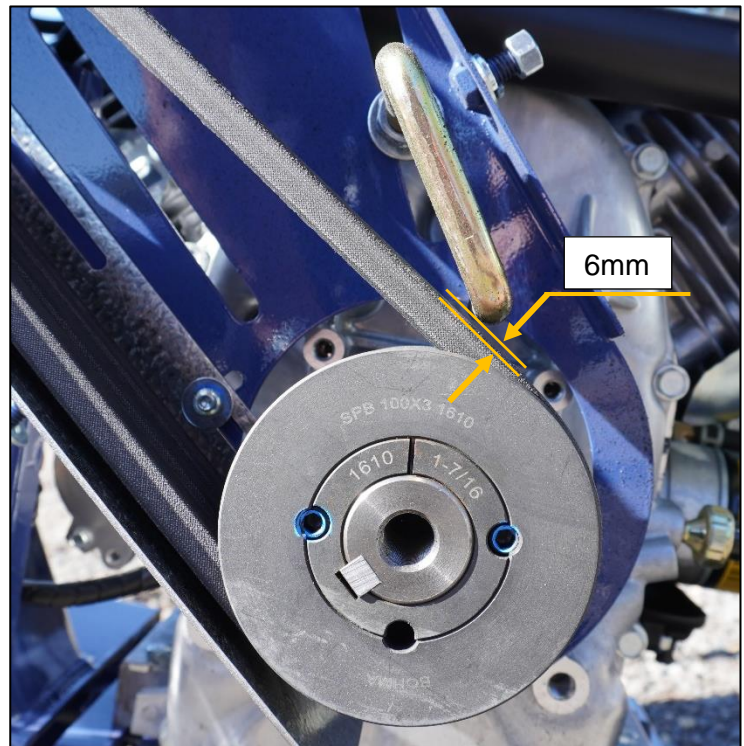
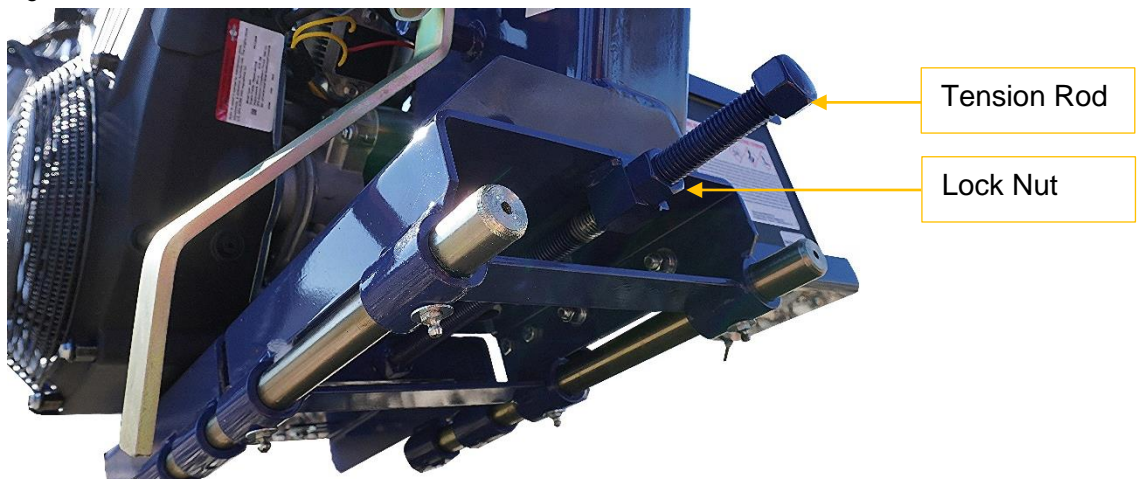
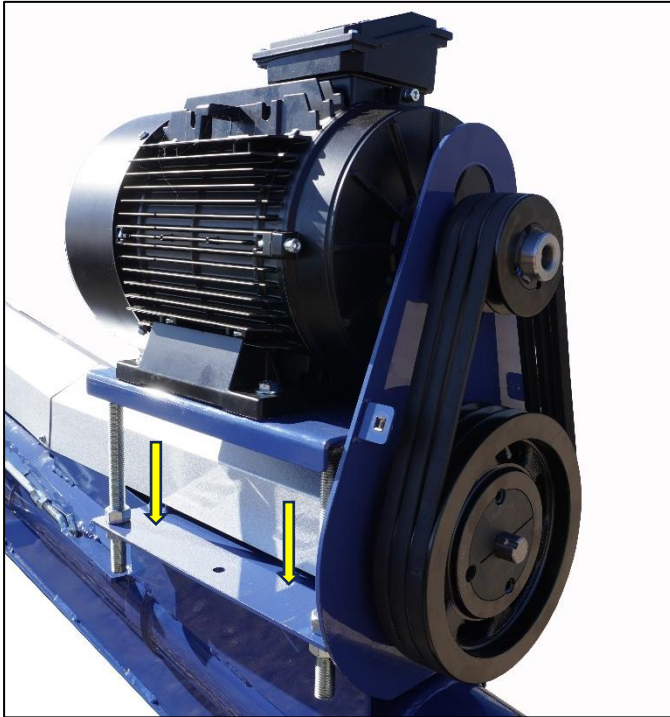

Figure 3.



4.6 Belt tensioning (electric augers)

The belts on the electric augers are tensioned by, winding the nuts up and down on the threaded rod. Once the belts are at the correct tension the nuts are locked into place.



4.7 Hydraulic drive system (hydraulic powered augers)

Inspect all hoses for damage; any damaged hoses must be replaced immediately. Pay particular attention to hose couplings and fittings, if in doubt replace it.

CAUTION: Replaced hoses and fittings must be matched to the specifications of the original. Any alternatives may not be suitable for the required pressure, and they may fail, causing damage and injury to machinery and personal. Always refer to equipment manufacturers or agents for correct specifications.

4.8 Hydraulic motor drive coupling

1. Re-tighten hydraulic motor mounting bolts.
2. Check joining link spring clip is fitted and is facing the direction of rotation.
3. Smear a layer of water-resistant grease on the surface of the coupling chain; this will reduce wear of the chain and sprockets.
4. Re-tighten motor and bearing mounting plate unit to the mounting flange.

4.9 Winch maintenance

The winch has been fully lubricated at the factory, but for continued smooth performance and increased working life, occasionally grease gears, reel shaft and handle thread.

CAUTION: Do not oil or grease brake mechanism. The winch must have a minimum of three wraps of cable on the drum, when the auger is in the transport position.

4.10 Winch cable

1. Check and replace if damaged.

4.11 Lifting track, track runner and pulleys

1. Check lifting track for wear.
2. Check cable 'D' shackles for wear and pin tightness.
3. Check pulleys for wear, both in the grooves and shafts. Grease pulley shafts regularly.
4. Check and re-tighten all bolts.
5. Lightly oil or grease all sliding and pivoting points.

4.12 Bearings

1. Remove drive shaft guard.
2. Inspect all bearings along the drive shaft from the engine to the drive train.
3. Ensure all grub screws are tight and the bearings are sound.
4. Replace drive shaft guard.

DANGER: Never operate the grain auger when the drive shaft guard has been removed.

4.13 Fasteners

1. Check and tighten all bolts, nuts, and grub screws on pulleys, belt tension unit, sprockets, lift arms, winch, wheel nuts and engine mounting bolts.

4.14 Wheel hubs

1. Re-pack every 1 – 3 years with lithium based grease.
2. Adjust wheel bearings as per instructions in the assembly section of this manual.

4.15 Tyre pressure

1. Correct pressure should be checked with a suitable pressure gauge and pressure set at 140kPa (20psi).

4.16 Engine servicing

Safe operating procedure:

1. Before attempting to service the engine, remove the ignition key and disconnect the spark plug lead.
2. Refer to engine manufactures manual for servicing and maintenance recommendations.
3. Never check or add oil with the engine running.

4.17 Lubrication

The engine is serviced with 10W30 oil. The oil should be changed after the initial run-in period of 8 hours. Thereafter, change oil after every 50 hours of operation.

4.18 Checking engine crankcase oil level

Check oil level before use and after every 5 hours of continuous operation, or more frequently if engine is exhausting white/blue smoke.

To check oil level

1. Position the auger on a level surface and raise the angle of the auger, by using the winch, until the engine is level. Make sure the engine is cool and oil has had time to drain into the sump, (allow at least 5 minutes after stopping the engine).
2. Before removing the dipstick, clean the area around the dipstick opening of any dirt or debris. Do not allow dirt or dust to enter the engine, or to collect on the dipstick.
3. Unscrew and remove the filler plug/dipstick and wipe off with a clean rag. Screw in, pause, then unscrew and remove the dipstick to check oil level.

4. **The actual oil level is indicated only when the dipstick is screwed in and not rested on top of the crankcase.**
5. The oil level should be kept within the safe range between the **High (H) and Low (L)** marks.

4.19 Changing oil and oil filter (if fitted)

Change the engine oil after every 50 hours of operation and the oil filter every 100 hours of operation.

CAUTION: Hot oil can burn, never drain engine oil when engine is hot, allow time for the engine to cool down before servicing. Oil only needs to be warm to drain easily.

1. Drain the oil while engine is warm, if the engine is cold run it for a few minutes to warm the oil.
2. Remove the dipstick and oil drain plug. Drain the oil into a suitable container.
3. Allow sufficient time for the oil to completely drain from the engine.
4. Remove the old oil filter and wipe clean the filter mounting surface of the engine. Apply a thin coating of new oil to the rubber gasket on the replacement oil filter. Screw on the oil filter until the rubber gasket contacts the sealing surface, then hand tighten an additional $\frac{3}{4}$ of a turn.
5. Re-install the oil drain plug, ensure it is correctly tightened.
6. Fill the crankcase through the filling point with new oil of the recommended viscosity. Up to 35 degrees Celsius ambient temperature use 10W-30 oil, over 35 degrees Celsius ambient temperature use 10W-40 oil. Correct viscosity will aid starting in cold weather and assure proper lubrication in hot weather.
7. Fill to the full mark on the dipstick. Refer to the previous page for the correct method to check the oil level.
8. Check the dipstick reading before pouring in the last 100ml of oil, fill only to the full mark. Never overfill the crankcase; overfilling can result in overheating and loss of power.
9. Start the engine and check for oil leaks around the oil filler and drain plug. Stop the engine and re-check the oil level, add if necessary.
10. When the engine is first operated with a new oil filter, the oil level will drop slightly as the filter fills with oil.

4.20 Air cleaner servicing

Safe operating procedure:

1. Never use petrol or low flash point solvents to clean the air pre-cleaner or any part of the air cleaner. A fire or an explosion could result.
2. Never run the engine without the air cleaner fitted. Rapid engine wear will result from contaminants such as dust and dirt being drawn into the engine.

Air cleaner servicing

The engine is equipped with a paper air cleaner element and oiled foam pre-cleaner. Clean and re-oil the pre-cleaner after every 24 hours of operation and replace yearly (or when dirty or damaged).

1. Release the air cleaner cover and remove.
2. Remove the foam element from the air cleaner cover and remove the paper element from the air cleaner case.
3. Clean the air filter elements (if they are to be re-used).
4. Foam element-Clean in warm soapy water, rinse and dry thoroughly or clean it in a non-flammable solvent and dry.

5. Always follow engine manufactures recommendations.
6. Paper element: Tap gently on a flat surface to dislodge dirt.
7. Do not wash the paper element, brush the dirt off, use air pressure or damage the side walls of the paper element. Replace the paper element if it is dirty or damaged. Replace element if in doubt.
8. Wipe dirt from the inside of the air cleaner body and cover using a moist rag. Be careful to prevent dirt from entering the air chamber that leads to the carburettor.
9. Re-install the air cleaner elements and cover, ensuring to secure the cover with screws or clips.

4.21 Spark plug service

NOTICE: Never use a spark plug of an incorrect heat range. Refer to engine manufacturers manual for recommended spark plug and servicing details.

1. Yearly, or every 100 operating hours, remove spark plugs, inspect, clean and reset gap or replace with a new plug.
2. Remove each spark plug cap, and using a spark plug wrench, remove each spark plug.
3. Visually inspect the spark plug. Discard the spark plug if there is apparent wear to the electrodes, or if the ceramic insulator is cracked or chipped. Clean the spark plug with a wire brush if it is to be re-used.
4. Measure spark plug gap with a feeler gauge. Correct as necessary by bending the side electrode. Correct gap setting should be 0.7-0.8mm.

4.22 Installing spark plug

1. Check that the spark plug washer is in good condition.
2. Screw the spark plug in by hand to prevent cross threading, never force the spark plug to start threading.
3. After the spark plug is seated, tighten with a spark plug wrench to compress the spark plug washer.
4. The spark plug must be securely tightened. An improperly tightened spark plug can become very hot and may damage the engine.

4.23 Replacing Oil – Reversible Gearbox

1. Using a suitable spanner unscrew breather from top of gearbox.
2. Using a suction pump or similar remove all oil from the gearbox.
3. Refill gearbox with 80W90 gear oil. For 6 & 8 inch augers oil quantity is 300ml & 1100ml for 10 & 12 inch augers.
4. Clean thread on breather and at oil fill point. Apply thread sealant to breather thread and screw back in. Ensure breather is tight and clean up any residual thread sealant.



Section 5: Storage

5.1 Long term storage

When not in use, the Grainline grain auger must be safely stored so that it will not fall accidentally. Care should be given to ensure it is stable and does not pose a risk of falling onto a person who is preparing it for use.

DANGER: Never leave the auger in the raised position when not in use, as this will lead to the auger falling over in strong winds. Always lower the auger fully to the down position, which is the safest way to store the auger.

The ideal location for storage of the grain auger is in a large, enclosed shed, i.e. empty grain or hay shed. If this is not possible and the auger is exposed to high winds, there are some steps that must be taken to ensure the complete safety in the storage of the auger.

1. The grain auger may need to be anchored down to prevent it from being blown over or rolling away. Ways in which this can be done is by securing the axle of the auger to two heavy objects at each end of the axle, as close as possible to the wheels. I.e. large concrete blocks, large sealed drums filled with water or anchored to the ground with large pins or stakes.
2. Place two objects at the front and back of each wheel to prevent the auger from rolling away. I.e. bricks or wooden chocks.

Section 6: Specifications

6.1 Standard 6 inch 30-40ft Transportable augers

Specifications	9m/30ft	11m/36ft	12m/40ft
Capacity	30 tonne/hour based on wheat at operating angle of 30 degrees		
Reach height @ 35°	5.2m	6.4m	7m
Finish	625 Polythane Paint – High Performance Acrylic Polyurethane Enamel		
Tube	1.6mm wall spiral welded		
Flighting	3mm continuous flight welded to 25nb centre pipe		
Intake Flighting	4.8mm Heavy duty flight		
Wheels	14 inch x 5 stud Sunraysia wheels with light truck tyres		
PTO input speed	540 RPM (For PTO Powered Augers)		
Hyd oil flow rate	40 litres per minute (For GMH Hydraulic Powered Augers)		
Gearbox Oil & Qty	SAE 80W/90 – 300ml		
Belts & pulleys	2B	2B	2B

6.2 Standard 8 inch 30-56ft Transportable augers

Specifications	9m/30ft	11m/36ft	12m/40ft	13m/43ft	14m/46ft	15m/50ft	17m/56ft
Capacity	70-80 tonne/hour based on wheat at operating angle of 30 degrees						
Reach height @ 35°	5.2m	6.4m	7m	7.6m	8.2m	8.7m	9.9m
Finish	625 Polythane Paint – High Performance Acrylic Polyurethane Enamel						
Tube	2mm wall spiral welded						
Flighting	3mm continuous flight welded to 40nb centre pipe						
Intake Flighting	4.8mm Heavy duty cupped flight						
Wheels	14 inch x 5 stud Sunraysia wheels with light truck tyres						
PTO input speed	540 RPM (For PTO Powered Augers)						
Hyd oil flow rate	60 litres per minute (For GMH Hydraulic Powered Augers)						
Gearbox Oil & Qty	SAE 80W/90 – 300ml						
Belts & pulleys	2B	2B	2B	2B	2B	2B	3B
Fuel tank	-	12Ltr	12Ltr	12Ltr	12Ltr	12Ltr	25Ltr
Top Chain	10B-1	10B-1	10B-1	10B-1	10B-1	10B-2	10B-2

6.3 Standard 10 inch 30-70ft Transportable augers

Specifications	9m/30ft	11m/36ft	12m/40ft	13m/43ft	15m/50ft	17m/56ft	18m/60ft	20m/65ft	21m/70ft
Capacity	120 tonne/hour based on wheat at operating angle of 30 degrees								
Reach height @ 35°	5.2m	6.4m	7m	7.6m	8.7m	9.9m	10.5m	11.6	12.2
Finish	625 Polythane Paint – High Performance Acrylic Polyurethane Enamel								
Tube	2mm wall spiral welded								
Flighting	3mm continuous flight welded to 50nb centre pipe								
Intake Flighting	4.8mm Heavy duty cupped flight								
Wheels	15 inch x 6 stud Sunraysia wheels with light truck tyres								
Gearbox Oil & Qty	SAE 80W/90 – 1100ml								
Belts & pulleys	2B	3B	3B	3B	3B	3B	3B	3B	3B
Fuel tank	12Ltr	25Ltr	25Ltr	25Ltr	25Ltr	25Ltr	25Ltr	25Ltr	25Ltr
Top Chain	10B-2	10B-2	10B-2	10B-2	10B-2	10B-2	10B-2	10B-2	10B-2

6.4 Standard 12 inch 36-50ft Transportable augers

Specifications	11m/36ft	12m/40ft	15m/50ft
Capacity	180 tonne/hour based on wheat at operating angle of 30 degrees		
Reach height @ 35°	6.4m	7m	8.7m
Finish	625 Polythane Paint – High Performance Acrylic Polyurethane Enamel		
Tube	2mm wall spiral welded	2mm wall spiral welded	3mm wall spiral welded
Flighting	3mm on 50nb centre pipe	3mm on 50nb centre pipe	4.8mm on 50nb centre pipe
Intake Flighting	4.8mm Heavy duty cupped flight		
Wheels	15 inch x 6 stud Sunraysia wheels with light truck tyres		
Gearbox Oil & Qty	SAE 80W/90 – 1100ml		
Belts & pulleys	3B	3B	3B
Fuel tank	25Ltr	25Ltr	25Ltr
Top Chain	10B-2	10B-2	10B-2

Notes:



1 Hartog Place, East Wagga Wagga NSW 2650, Australia

Phone: 1800 810 498

Email: sales@grainline.com.au

Website: www.grainline.com.au



Scan to request replacement manuals & spare parts.
