



HYDRAULIC / PNEUMATIC Over the Shaft (OTS)
PILOTLESS POWER TAKE OFF
Installation and Maintenance Manual

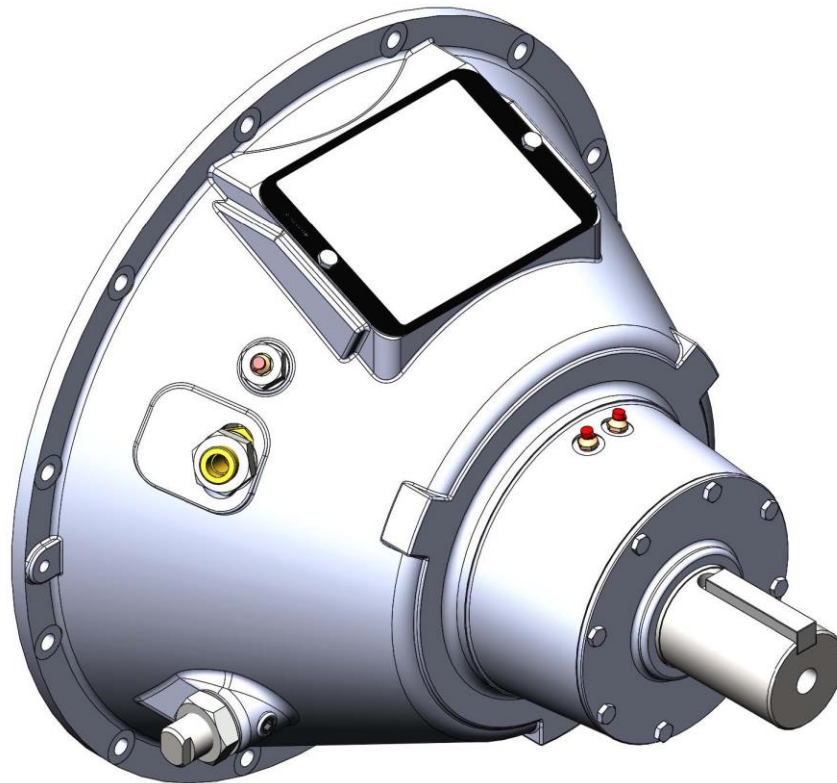

Table of Contents

	Page#
1.0 INTRODUCTION	4
1.1 The WPT Power PTO	
1.2 Product identification numbers	
1.3 Bill of materials	
2.0 SPECIFICATIONS	4
2.1 Flywheel dimensions	
2.2 Flywheel housing / Bellhousing dimensions	
2.3 PTO performance table	
3.0 MAINTENANCE	5
3.1 Lubrication prior to installation	
3.2 Main bearings, engagement bearing lubrication and Chart 1	
3.3 Amount and frequency of lubrication	
3.4 Washing PTO	
4.0 INSPECTION	6
4.1 Preparation	
4.2 Flywheel and flywheel housing checks	
4.3 Flywheel to housing face run out	
4.4 Flywheel housing bore run out	
4.5 Flywheel face run out	
4.6 Engine crankshaft endplay	
4.7 Flywheel pilot bore run out	
5.0 INSTALLATION	7
5.1 Clutch disc alignment	
5.2 Clutch engagement	
5.3 Drive ring installation	
5.4 PTO installation	
5.5 Interference check	
5.6 Bellhousing bolt torques	
5.7 Support plate requirements	
6.0 CLUTCH OPERATION	8
6.1 Engaging the clutch	
6.2 RPM limit	
6.3 Fully engaged clutch	
6.4 Actuator supply pressure	
7.0 PTO ADJUSTMENT	9
7.1 Clutch adjustment	
Friction Disc wear	

Table of Contents

	Page#
8.0 DISASSEMBLY	9
8.1 Remove PTO from engine	
8.2 Remove clutch from PTO	
8.3 Remove shaft from PTO housing	
9.0 ASSEMBLE PTO	11
9.1 Install shaft in PTO housing	
9.2 Install clutch	
9.3 Check runout	
10.0 GENERAL STORAGE GUIDELINES	12
11.0 CHART 2 BOLT TORQUE VALUES	13
12.0 CHART 3 SPECIFICATIONS	14
13.0 CHART 4 FLYWHEEL AND HOUSING DIMENSIONS.	14
14.0 FLYWHEEL AND HOUSING DRAWING	15
15.0 211/311/214/314 OTS PL PTO CLUTCH PACK AND PARTS LIST .	16
16.0 211/311/214/314 OTS PL PTO DRAWING AND PARTS LIST	17
17.0 SIDE LOAD DATA 211 OTS PILOTLESS PTO	18
18.0 SIDE LOAD DATA 214 OTS PILOTLESS PTO	18
19.0 SIDE LOAD DATA 311 OTS PILOTLESS PTO	18
20.0 SIDE LOAD DATA 314 OTS PILOTLESS PTO	19
21.0 TROUBLESHOOTING GUIDE	20

1.0 INTRODUCTION

- 1.1 The WPT Power PTO is the most rugged PTO available on the market today. Follow the procedures detailed in this Installation Maintenance Manual for years of service.
- 1.2 When ordering parts, use the part number from the Bill of Materials supplied with this unit. Also, please include the part number and the serial number from the unit itself. These will be found on the metal hand hole cover on the bell housing. Your authorized WPT Distributor can provide a copy of the Bill of Materials if the one provided should become lost.
- 1.3 When performing installation and maintenance functions, refer to the drawings at the back of this manual, pages 16 thru 17. The references on the drawing in this manual DO NOT correspond to the references on the assembly drawing and Bill of Materials. Do not use the item numbers from the drawing in this manual for ordering parts.

DANGER:

To avoid damage or personal injury, ensure that adequate lifting devices and hand tools are available.

DANGER:

Read these instructions thoroughly and review until you fully understand all warning and hazards before proceeding with the work described in this manual. Failure to follow these instructions in this manual can result in unreasonable exposure to hazardous conditions and/or personal injury and/or death.

Throughout there are a number of HAZARD WARNINGS that must be read and adhered to in order to prevent possible loss of equipment and/or personal injury and /or loss of life. The three warning words are “DANGER”, “WARNING” and “CAUTION”. They are used to indicate the severity of the hazard and are preceded by a safety alert symbol. 

- “DANGER” – Denotes the most serious injury hazard and is used when serious injury or death **WILL** result from misuse or failure to follow the specific instructions set forth in this manual.
- “WARNING” – Denotes when serious injury or death **MAY** result from misuse or failure to follow the specific instructions set forth in this manual.
- “CAUTION” – Denotes when injury, product or equipment damage may result from the misuse or failure to follow the specific instructions set forth in this manual.

It is the responsibility of the personnel involved in the installation, operation and maintenance of this equipment, on which this PTO is mounted, that they must fully understand the warnings and dangers that are listed in this manual and are aware of what the correct procedures must be to safely install, operate and maintain this equipment.

2.0 SPECIFICATIONS

- 2.1 See Chart 4 for flywheel dimensions, page 14 and drawing page 15.
- 2.2 See Chart 4 for flywheel housing dimensions, page 14 and drawing page 15.
- 2.3 The maximum RPM is listed in Chart 3 for your PTO size, page 14.
- 2.4 Maximum actuator pressure not to exceed 200 lb/in² [13.79 bar].

3.0 MAINTENANCE

3.1 The WPT PTO requires lubrication with grease in accordance with Table 1 below. Prior to installation, grease the main shaft bearings and Over-The-Shaft (OTS) engagement bearings. Apply grease to each fitting until grease just appears at the respective seal surfaces. Although the PTO is normally lubricated at the factory, this step will ensure that all moving parts are properly lubricated for initial use.

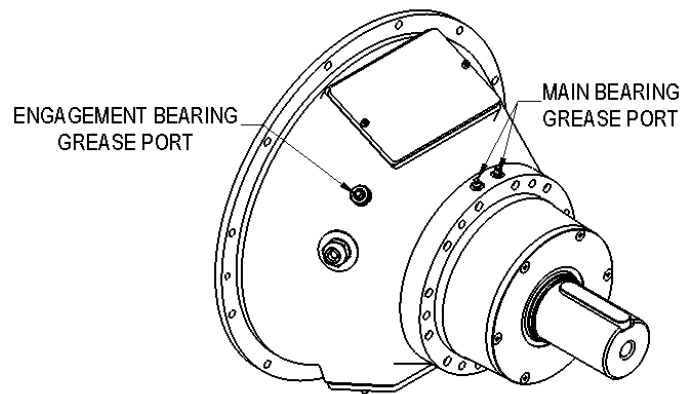

Lubrication Type

Conditions	Ambient < -25°F (-32°C)	-25°F (-32° C) < Ambient < 90°F (32°C) AND Bearing Temperature < 180°F (82°C)	90°F (32°C) < Ambient OR < 180°F (82°C) Bearing Temperature
Grease Recommended	Lubriplate MAG-1 OR Equivalent	NLGI #2 Lithium Base Grease OR Lubriplate 1200-2 OR Equivalent	Phillips 66 Multiplex 220 NLGI #2 Lithium Base Grease OR Shell Gadus S3 V220C OR Equivalent

Table 1

3.2 During normal operation, apply grease to the OTS engagement bearings, two shots per 100 hours of operation. Grease the main bearings (located on the clutch shaft) as shown in **Chart 1** below.

RECOMMENDED LUBRICATION INTERVALS		
CLUTCH SIZE	GREASE SHOTS PER ZERK	HOURS OF OPERATION
OTS-PL 211	6	100
OTS-PL 311	6	100
OTS-PL 214	8	50
OTS-PL 314	8	50

CHART 1

3.3 Amount and frequency of lubrication are only a recommendation. Actual requirements will vary, due to load and operating conditions. Monitor new units for heat and wear for a period of time.

3.4 When washing, the PTO be careful not to spray directly into where the solution will get inside the bellhousing and contaminate the clutch, grease fittings, bearings, or shafts.

4.0 INSPECTION

- 4.1 Preparation.** Upon receipt of your WPT product, inspect for and report any evidence of damage. To avoid damage or personal injury, ensure that adequate lifting devices and hand tools are available. Compare the flywheel and flywheel housing to the bell housing and drive ring, respectively to ensure that you have the correct size unit.
- 4.2 Check engine flywheel and flywheel housing alignment.** It is strongly recommended that dial indicator checks be made prior to installation of the PTO, especially on new engines or when a previous PTO failure might indicate an alignment problem.
- 4.3 Engine flywheel to housing face run out inspection.** Mount the indicator base on the face of the flywheel and position the dial indicator tip perpendicular to the flywheel housing mounting face. Rotate the flywheel 360 degrees while holding pressure against the crankshaft thrust bearing. The total indicator reading should not exceed the values listed in the table shown below in Section 4.4.

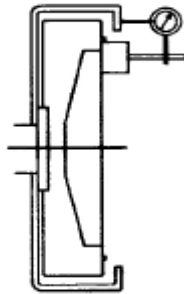

- 4.4 Check engine flywheel housing bore runout.** Mount the indicator base on the face of the flywheel and position the dial indicator tip so its movement is perpendicular to the pilot bore of the flywheel housing. Rotate the flywheel through 360 degrees.

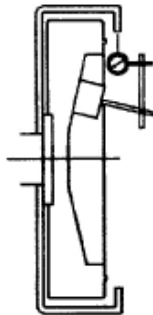

The total indicator reading should not exceed:

SAE "00" Housing:	0.019 inches (0.483 mm)
SAE "0" Housing:	0.016 inches (0.406 mm)
SAE "1" Housing:	0.012 inches (0.305 mm)
SAE "2" Housing:	0.011 inches (0.279 mm)
SAE "3" Housing:	0.010 inches (0.254 mm)
SAE "4" Housing:	0.009 inches (0.229 mm)
SAE "5" Housing:	0.008 inches (0.203 mm)
SAE "6" Housing:	0.007 inches (0.178 mm)

(Reference: SAE J617 table 1A)

4.5 Check engine flywheel face runout.

Mount the indicator base on the flywheel housing and position the dial indicator tip so that its movement is perpendicular to the face of the flywheel. Position the indicator tip near the drive ring mounting bolt circle diameter. Rotate the flywheel 360 degrees while holding pressure against the crankshaft thrust bearing.

The total indicator reading should not exceed 0.0005 inches (0.013 mm) per inch of measured diameter.

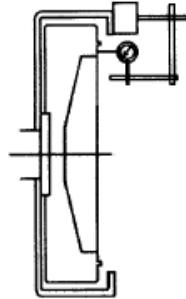

4.6 Check engine crankshaft endplay.

Measure and document the engine's crankshaft endplay before installing PTO. Using dial indicator as shown in 4.5 move the crankshaft back against the rear main bearing and then move the crankshaft to the front of the engine.

4.7 Check engine flywheel pilot bore runout.

Mount the indicator base on the flywheel housing and position the dial indicator tip so its movement is perpendicular to the pilot bore diameter, to measure pilot bore runout. Rotate the flywheel through 360 degrees.

The total indicator reading should not exceed 0.005 inches (0.127 mm).

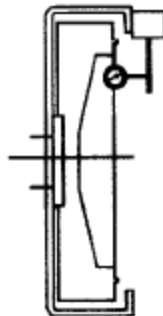

5.0 INSTALLATION

- 5.1 Use the drive ring provided with the PTO or remove the drive ring from the engine flywheel to use as an alignment gauge. Place the drive ring over the friction discs. Center the drive ring relative to the O.D. of the clutch body.
- 5.2 Connect actuator and engage the clutch by pressurizing OTS chamber. Remove the drive ring. Do not disengage clutch until installation is complete. See drawing for connection size.

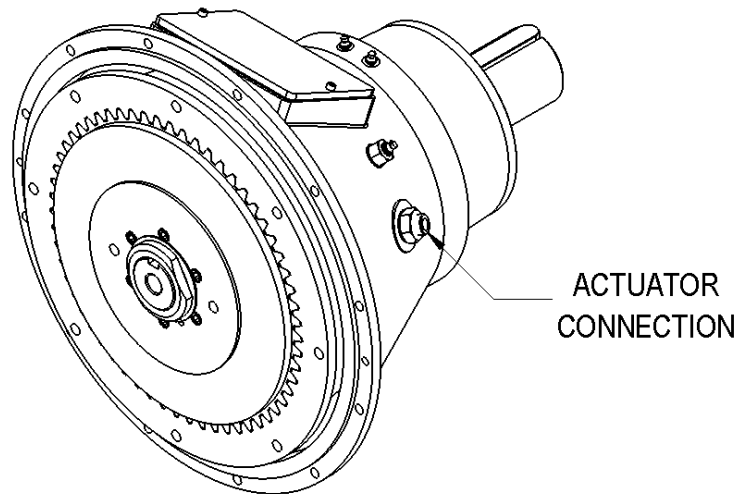

Image may vary

- 5.3 Install the drive ring on the engine flywheel making sure that the ring is seated in the locating bore. Use SAE Grade 5 bolts (or equivalent) with lock washers and torque to the specifications in **Chart 2** on page 13 or to the engine manufacturers torque recommendation. Use the engine manufacturer's torque recommendation if different from that in **Chart 2**.
- 5.4 Remove inspection cover nameplate from the PTO bellhousing and slowly draw the PTO toward the engine; this can be done by installing 3 or 4 equally spaced lengths of all-thread into the flywheel housing. Install nuts and tighten these while supporting the weight of the PTO with a hoist or cribbing.
- 5.5 As the PTO is drawn toward the engine, ensure that the friction discs engage the teeth on the drive ring without binding or interference.
- 5.6 When the PTO is fully in place, remove the studs if used and replace with SAE Grade 5 bolts (or equivalent) with lock washers and torque to the value in **Chart 2** on page 13. Use the engine manufacturer's torque recommendation if different from that in **Chart 2**.
- 5.7 Support plate is required for side load applications and recommended for in-line applications.

WARNING:

The WPT PTO is capable of side load and inline power transmission applications. Special care should be exercised when installing the PTO in an inline application. Due to engine movement and other factors that may cause misalignment, WPT recommends that a flexible coupling or drive shaft be used to join the PTO and driven shaft. If a coupling is used, ensure that it has sufficient horsepower capacity and that shafts are in line within the limits specified by the coupling manufacturer. If you are unsure about the procedure to align these shafts, consult the coupling manufacturer or WPT Power.

6.0 CLUTCH OPERATION

- 6.1 Where high inertia loads must be started, engaging the clutch at idle speed may stall the engine. High inertia loads may be brought up to speed by engaging the clutch for short periods, (1 second) at intervals long enough to prevent excessive heat buildup in the friction discs. With extremely high loads, the engine may have to be operated at higher speeds while engaging the clutch.
- 6.2 Do not engage clutch above 1100 RPM.
- 6.3 Once the load is turning with the clutch fully engaged, the engine RPM may be increased.

CAUTION:

UNDER NO CIRCUMSTANCES should the clutch be slipped for more than four seconds' maximum without either fully engaging the clutch or completely disengaging the clutch to allow it to cool. Any excessive vibration in the PTO should be cause for investigation. All rotating parts of the WPT PTO are balanced at the factory.

6.4 ACTUATOR SUPPLY PRESSURE

- 6.4.1 Maximum actuator pressure not to exceed 200 lb/in² [13.79 bar].
- 6.4.2 Bearing life is dependent on actuator pressure. Actuator pressure should only be sufficient to prevent the clutch from slipping. Engagement pressure puts axial force on the bearings, the higher the pressure the shorter the bearing life.
- 6.4.3 Contact WPT Power Applications Engineering for questions or assistance.

7.0 PTO ADJUSTMENT

7.1 Clutch Adjustment

- The WPT PTO uses a piston and cylinder for engagement and is self-adjusting.

IMPORTANT: As clutch wears, replace friction disc when clutch slips or begins to lose torque.

8.0 DISASSEMBLY

(Refer to PTO Illustration on pages 16 through 17 of this manual)

Use a hoist or other suitable lifting equipment to support the weight of the power take-off. Attach lifting devices at several places or use cribbing to support the PTO in a horizontal position during removal.

DANGER:

The PTO is heavy. Use approved lifting eyes and procedures to prevent accident or injury.

8.1 Remove the PTO from the engine

- 8.1.1 Remove hydraulic/pneumatic engagement hose and other connections to the PTO.
- 8.1.2 Remove drive shaft or drive belts from PTO output shaft.
- 8.1.3 Remove the mounting bolts attaching PTO to flywheel housing, removing those located near the top last. The PTO should separate from the flywheel housing. If the PTO doesn't separate, gently pry the flanges apart until the housing is removed from the engine flywheel housing pilot diameter.

WARNING:

Use care when removing the PTO from the engine to avoid damage to grease fittings, friction disc teeth, and other components.

8.2 Remove the clutch from the PTO and Disassemble

- 8.2.1 Bend hub lock washer tab away from hub locknut.
- 8.2.2 Remove hub locknut.
- 8.2.3 Remove hub lock washer.
- 8.2.4 Remove the clutch assembly using a gear puller and the tapped holes that are provided in the backplate.
- 8.2.5 Remove three flat head socket cap screws, retaining plate, and retaining ring from piston cylinder assembly, allowing the piston cylinder floating plate assembly to separate from the clutch.
- 8.2.6 Remove socket head cap screws and floating plate from piston cylinder assembly.
- 8.2.7 Disassemble bearings, piston assembly, cylinder, bearing hub and end plate.
- 8.2.8 Remove center plates, friction disc and backplate from hub.

8.3 Remove the shaft from the PTO housing

- 8.3.1 Remove the bolts from end cap on customer mounting end of shaft.
- 8.3.2 Remove key from clutch end of shaft.
- 8.3.3 Strike clutch end of shaft with soft faced hammer or use a suitable bearing press to loosen shaft and bearings from PTO housing. See sketch below for direction.

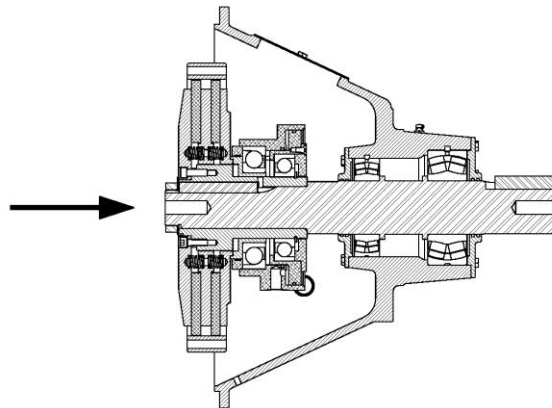

- 8.3.4 Remove shaft and bearings from PTO housing.
- 8.3.5 Using a suitable bearing press, remove bearings from shaft.

9.0 ASSEMBLE THE PTO

9.1 Install shaft in PTO housing

Reverse steps 8.3.1 through 8.3.5 on page 10.

9.2 Install Clutch

Install clutch by reversing steps 8.2.1 through 8.2.8 on page 10.

9.3 Check runout between clutch and bellhousing

9.3.1 Hang PTO from hoist with clutch end down.

9.3.2 Place magnetic base on clutch with dial indicator on bellhousing pilot, zero dial indicator.

9.3.3 Rotate bellhousing 360 deg. watching the dial indicator needle movement. Total Indicator Reading (T.I.R.) tolerance is .0005" per inch of diameter.

9.3.4 Move indicator to the bellhousing face and zero the needle.

9.3.5 Rotate bellhousing 360 deg. watching the dial indicator needle movement. T.I.R. tolerance is .0005" per inch of diameter.

10.0 General Storage Guidelines

Upon receipt of parts or assemblies, they should be inspected for corrosion or other related damage. If any problem is detected, contact vendor.

It is the owner's primary responsibility to store and protect the PTO product.

Products should be stored in a manner that it is protected from the environment and outside sources, which may include but are not limited to the following:

- **Environmental storage requirements should be maintained as follows:**
 - **No exposure to rainwater**
 - **Temperatures 32F° (0C°) to 110F° (43C°)**
 - **Below 50% average humidity**
 - **Average sunlight**

- **Hazards that require addition protection:**
 - **Dust and debris**
 - **Oil, water, saltwater, acids, or other chemicals**
 - **Any other foreign items which may damage the product**
 - **Other measures include covering the product to prevent ingress of foreign matter**

- **Additional Protection Measures for Long-Term Storage
(For storage exceeding one month):**
 - **Coat exposed metal with Cosmoline RP-342 "HEAVY" Military-Grade Rust Preventive Aerosol Spray, or equal**
 - **Coating of painted surfaces is not required or recommended**
 - **Visually inspect the product for degradation once every three-months**

11.0 BOLT TORQUE VALUES

TORQUE VALUES FOR SOCKET HEAD AND HEX HEAD CAPSCREWS						
SOCKET HEAD CAP SCREWS						
BOLT SIZE INCHES	As Received			Lubricated**		
	lbf-ft	lbf-in	N-m	lbf-ft	lbf-in	N-m
1/4	13	150	17	10	120	13
5/16	23	305	34	18	244	27
3/8	45	545	62	36	436	49
7/16	70	840	95	56	672	76
1/2	108	1300	147	86	1040	117
9/16	155	1860	210	124	1488	168
5/8	211	2530	286	168	2024	228
3/4	367	4400	497	293	3520	397
7/8	583	7000	791	466	5600	632
1	867	10400	1175	693	8320	940
1 1/8	1242	14900	1684	993	11920	1347
1 1/4	1750	21000	2374	1400	16800	1899
1 3/8	2317	27800	3142	1853	22240	2513
1 1/2	3042	36500	4125	2433	29200	3300
1 3/4	4950	59400	6714	3960	47520	5371
2	7492	89900	10161	5993	71920	8128
HEX HEAD CAP SCREWS - Grade 8						
BOLT SIZE INCHES	As Received			Lubricated**		
	lbf-ft	lbf-in	N-m	lbf-ft	lbf-in	N-m
1/4	8	100	11	6	80	9
5/16	17	200	23	13	160	18
3/8	30	360	41	24	288	32
7/16	48	570	64	38	456	51
1/2	83	990	112	66	792	89
9/16	107	1285	145	85	1028	116
5/8	143	1714	194	114	1371	155
3/4	256	3070	347	204	2456	277
7/8	417	5000	565	333	4000	452
1	625	7500	848	500	6000	678
HEX HEAD CAP SCREWS - Grade 5						
BOLT SIZE INCHES	As Received			Lubricated**		
	lbf-ft	lbf-in	N-m	lbf-ft	lbf-in	N-m
1/4	6	71	8	5	56	6
5/16	12	142	16	9	113	12
3/8	22	260	29	17	208	23
7/16	34	410	46	27	328	36
1/2	53	636	72	42	508	57
9/16	74	890	101	59	712	80
5/8	104	1250	141	83	1000	112
3/4	183	2200	249	146	1760	199
7/8	298	3570	403	238	2856	322
1	440	5280	597	352	4224	477
1 1/8	553	6640	750	442	5312	600
1 1/4	775	9300	1051	620	7440	840
1 3/8	1012	12140	1372	809	9712	1097
1 1/2	1350	16200	1831	1080	12960	1464

** NOTE: For Loctite use lubricated values

Chart 2

12.0 SPECIFICATIONS

Model/ Size	Available SAE Housing Sizes	Input Torque at 100 lbf/in ² lbf·ft (N·m)	Input Torque at 200 lbf/in ² lbf·ft (N·m)	Maximum Speed rpm	Approx. Net Weight lb (kg)
OTS-PL 211	3	930 (1260)	1400 (1900)	2500	201 (91)
OTS-PL 211	2	930 (1260)	1400 (1900)	2500	208 (94)
OTS-PL 314	1	1850 (2510)	2780 (3770)	2300	410 (186)
OTS-PL 314	0	1850 (2510)	2780 (3770)	2300	448 (203)

Contact WPT for applications requiring higher speeds.

CHART 3

13.0 FLYWHEEL AND HOUSING DIMENSIONS

FLYWHEEL DIMENSIONS					
Clutch size	A	B	C	N1	H1
6"	7.25 (184.2)	8.500 (215.90)	7.875 (200.02)	6	5/16 – 18 NC
7"	8.12 (206.2)	8.750 (222.25)	9.500 (241.30)	8	5/16 – 18 NC
8"	8.88 (225.6)	9.625 (244.48)	10.375 (263.52)	6	3/8 – 16 NC
10"	10.88 (276.4)	11.625 (295.28)	12.375 (314.32)	8	3/8 – 16 NC
11"	12.38 (314.5)	13.125 (333.38)	13.875 (352.42)	8	3/8 – 16 NC
14"	16.12 (409.4)	17.250 (438.15)	18.375 (466.72)	8	1/2 - 13 NC
FLYWHEEL HOUSING DIMENSIONS					
Housing size	D	E	N2	H2	
6	10.500 (266.70)	11.250 (285.75)	8	3/8 – 16 NC	
5	12.375 (314.33)	13.125 (333.38)	8	3/8 – 16 NC	
4	14.250 (361.95)	15.000 (381.00)	12	3/8 – 16 NC	
3	16.125 (409.58)	16.875 (428.63)	12	3/8 – 16 NC	
2	17.625 (447.68)	18.375 (466.73)	12	3/8 – 16 NC	
1	20.125 (511.18)	20.875 (530.22)	12	7/16 - 14 NC	
1/2	23.000 (584.20)	24.375 (619.12)	12	1/2 - 13 NC	
0	25.500 (647.70)	26.750 (679.45)	16	1/2 - 13 NC	
00	31.000 (787.40)	33.500 (850.90)	16	1/2 – 13 NC	

CHART 4

NOTE: See following page for flywheel and housing drawing.

14.0 FLYWHEEL AND HOUSING DRAWING

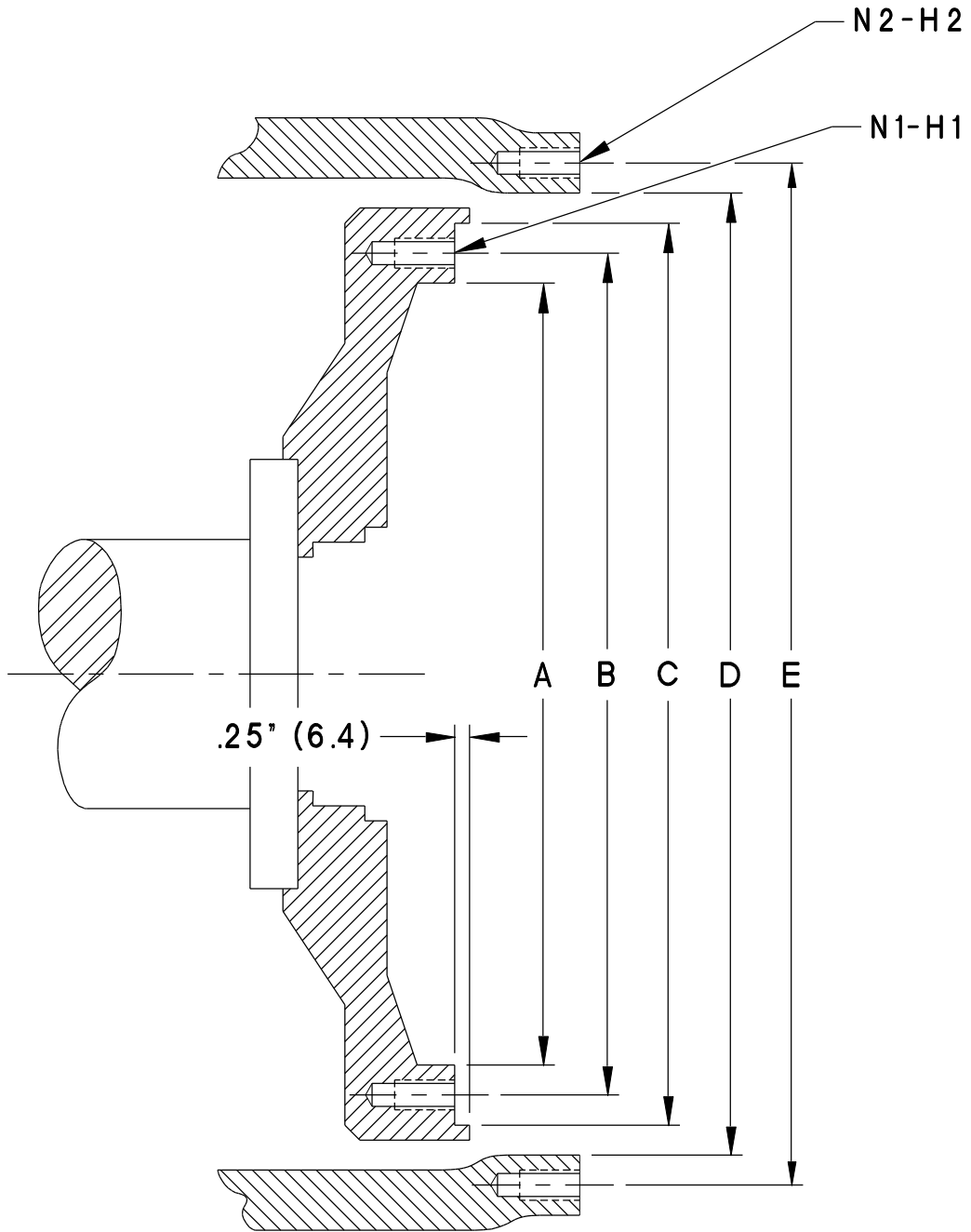

**15.0 211/311/214/314 OTS PL PTO - CLUTCH PACK AND PARTS LIST
(2 plate shown)**

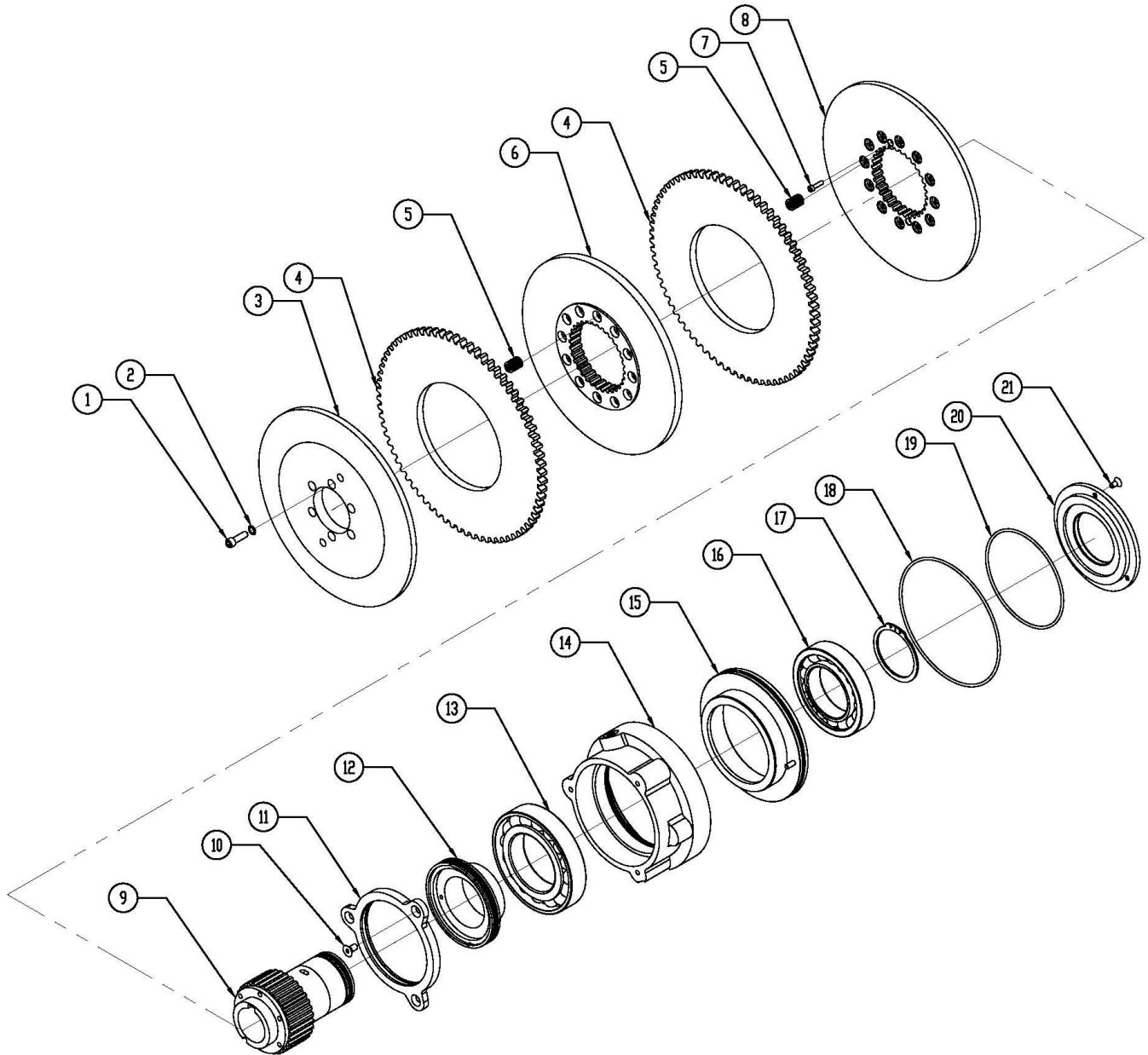

Item	Description	Qty	Item	Description	Qty
1	SHCS	6	12	Bearing Hub	1
2	Lock Washer	6	13	Ball Bearing	1
3	Backplate	1	14	Cylinder	1
4	Friction Disc	2	15	Piston Assembly	1
5	Release Spring	24	16	Ball Bearing	1
6	Center Plate	1	17	Ring Retainer	1
7	SHCS	2	18	O-Ring	1
8	Floating Plate	1	19	O-Ring	1
9	Hub	1	20	Cover	1
10	FHSCS	3	21	FHSCS	3
11	Front End Cover	1			

**16.0 211/311/214/314 OTS PL PTO - PARTS LIST
(3 PLATE SHOWN)**

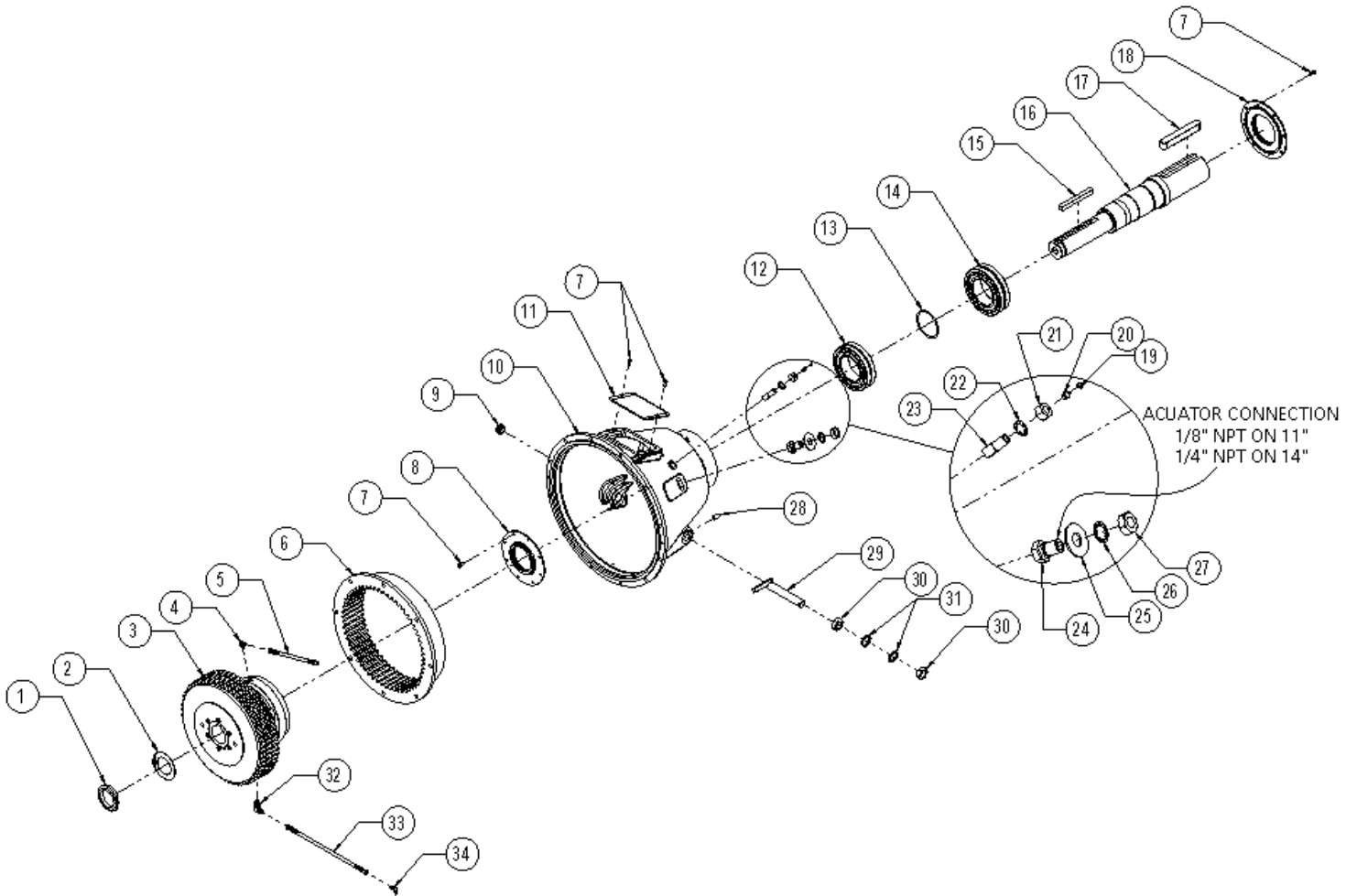

Item	Description	Qty	Item	Description	Qty
1	Nut, hub	1	18	End Cap	1
2	Lock washer, hub	1	19	Cap, Grease	3
3	Clutch Pack Assembly	1	20	Zerk, Grease	3
4	Elbow, 90 Deg.	1	21	Nut	1
5	Hose Assembly	1	22	Washer, Lock	1
6	Ring, drive	1	23	Bushing	1
7	HHCS	18	24	Adapter, Fitting	1
8	End Cap, Bearing	1	25	Washer	1
9	Plug	1	26	Washer, Lock	1
10	Bellhousing	1	27	Nut	1
11	Nameplate, Instruction	1	28	Set Screw	1
12	Bearing	1	29	Stud, Anti-Rotation Assembly	1
13	Retaining Ring	1	30	Nut	2
14	Bearing	1	31	Washer	2
15	Key, Clutch	1	32	Elbow, 90 Deg.	1
16	Shaft, Clutch	1	33	Hose Assembly	1
17	Key, Output	1	34	Elbow, 90 Deg.	1

17.0 SIDELOAD DATA - 211 OTS PILOTLESS PTO

ALLOWABLE SIDE PULL - lb [kg]							CALC FILE: W11-CG-211_A
RPM	"X" DISTANCE - in [mm]						
	11" [279]	12" [305]	13" [330]	14" [356]	15" [381]	16" [406]	
2500	7963 [3612]	6345 [2878]	5274 [2392]	4512 [2047]	3943 [1788]	3501 [1588]	
2300	8164 [3703]	6506 [2951]	5408 [2453]	4627 [2099]	4043 [1834]	3590 [1628]	
2100	8390 [3806]	6686 [3033]	5557 [2521]	4755 [2157]	4154 [1884]	3689 [1673]	
1800	8432 [3825]	6720 [3048]	5585 [2533]	4778 [2167]	4175 [1894]	3707 [1682]	

Side load rating and torque are dependent on the Service Factor.
Contact WPT Power Applications Engineering for questions or assistance.

18.0 SIDELOAD DATA - 311 OTS PILOTLESS PTO

ALLOWABLE SIDE PULL - lb [kg]					
RPM	"X" DISTANCE - in [mm]				
	15" [381]	17" [432]	19" [483]	21" [533]	23" [584]
2500	6516 [2956]	4537 [2058]	3480 [1578]	2822 [1280]	2374 [1077]
2300	6681 [3030]	4652 [2110]	3568 [1618]	2894 [1313]	2434 [1104]
2100	6866 [3114]	4781 [2168]	3667 [1663]	2974 [1349]	2501 [1135]
1800	7191 [3262]	5007 [2271]	3840 [1742]	3115 [1413]	2620 [1188]

Chart taken from W11-CG-311_D
Side load rating and torque are dependent on the Service Factor.
Contact WPT Power Applications Engineering for questions or assistance.

19.0 SIDELOAD DATA - 214 OTS PILOTLESS PTO

ALLOWABLE SIDE PULL - lb [kg]					CALC FILE: W14-CG-211_A	
RPM	"X" DISTANCE - in [mm]					
	16" [406]	18" [457]	20" [508]	22" [559]	24" [610]	26" [660]
2500	5965 [2706]	4434 [2011]	3528 [1600]	2930 [1329]	2505 [1136]	2187 [992]
2300	6117 [2774]	4546 [2062]	3617 [1641]	3004 [1362]	2568 [1165]	2243 [1017]
2100	6286 [2851]	4672 [2119]	3718 [1686]	3087 [1400]	2639 [1197]	2305 [1045]
1800	6583 [2986]	4893 [2219]	3893 [1766]	3233 [1466]	2764 [1254]	2414 [1095]

Side load rating and torque are dependent on the Service Factor.
Contact WPT Power Applications Engineering for questions or assistance.

20.0 SIDELOAD DATA – 314 OTS PILOTLESS PTO

ALLOWABLE SIDE PULL - lb [kg]		CALC FILE: W14-CG-303_A			
RPM	"X" DISTANCE - in [mm]				
	16" [406]	18" [457]	20" [508]	22" [559]	24" [610]
2500	7970 [3615]	5721 [2595]	4463 [2024]	3658 [1659]	3099 [1406]
2300	8171 [3707]	5866 [2661]	4576 [2075]	3750 [1701]	3177 [1441]
2100	8398 [3809]	6029 [2735]	4702 [2133]	3854 [1748]	3265 [1481]
1800	8795 [3989]	6314 [2864]	4925 [2234]	4037 [1831]	3420 [1551]

Side load rating and torque are dependent on the Service Factor.
 Contact WPT Power Applications Engineering for questions or assistance.

21.0 TROUBLESHOOTING GUIDE

Problem	Possible Cause	Remedy
PTO Will Not Engage/Disengage	Worn or damaged friction discs	Inspect friction discs and replace as needed
	Debris in clutch pack	Inspect clutch pack and remove debris
Ringling or Knocking Sound While Disengaged	Normal operational sound	Engage PTO
Grinding/Scraping Sounds While Engaged or Disengaged	Worn PTO main bearings	Inspect main bearings and replace as needed
Clutch Slips, Burnt Smell, and/or Smoke from PTO	Improper engagement pressure	Check engagement pressure and adjust as necessary
	Worn or damaged friction discs	Inspect friction discs and replace as needed
Excessive Vibrations	Worn engine bearings	Inspect endplay and runout on engine flywheel, replace as needed
	Worn PTO main bearings	Inspect main bearings and replace as needed
	Improper alignment	Check alignment, adjust as needed
Split Friction Disc or Broken Teeth	Worn drive ring	Inspect drive ring teeth and replace as needed
	Engagement speed is too high	Reduce to 1100 r/min
	Improper alignment	Check alignment, adjust as needed
	No support outboard support plate	Check if unit requires outboard support, install if needed
	High inertia or shock load starts	Contact WPT Power Applications Engineering for support
PTO Self Engages	Improper engagement pressure	Check engagement pressure and adjust as necessary
	Worn or damaged friction discs	Inspect friction discs and replace as needed
Frequent Adjustments Needed to Engagement Pressure	Engagement speed is too high	Reduce engagement speed to below 1000 r/min
Clutch Will Not Fully Seat on Bell Housing	Flywheel bore depth too shallow	Measure bore depth, contact WPT Power Applications Engineering
Bearing Carrier Hot	Too much or too little grease	Remove/Add Grease
	Improper belt tension	Adjust belt tension according to belt manufactures recommendations
	Worn PTO main bearings	Inspect main bearings and replace as needed
Excessive Grease Leaking	Over greased	Run at idle speed until grease outflow stops



WPT Power
1600 Fisher Road - Wichita Falls, TX 76305
P.O. Box 8148 - Wichita Falls, TX 76307 Ph. 940-761-1971
www.WPTpower.com